

ENGLISH



Customer product
manual P/N 10127

Release 01/2026



Low pressure dense phase conveying system

NEA 120

This document is subject to change without notice.
Visit <http://www.vernetechnology.it> for the latest version and available languages

NEA 120 peristaltic dense pump

CONTACTS

ADMINISTRATIVE HEADQUARTERS:

Verne Technology S.r.l.
Via Montenapoleone, 8
20121 - MILANO (MI) - ITALY-
Tel. +39 352 0208394 | Fax +39 (0)2-784087

e-mail: info@vernetechnology.it
www.vernetechnology.it

LOGISTICS Dpt:

(shipping and delivery)

Via Calamandrei, 11
20092 - Cinisello B. (MI) - ITALY
Tel. +39 340 3668736

e-mail: info@vernetechnology.it

Table of Contents

Safety	
Qualified Personnel	1
Intended Use	1
Regulations and Approvals	1
Personal Safety	1
Fire Safety	2
Grounding	2
Action in the Event of a Malfunction	3
Disposal	3
Disposal	
Pump Components NEA 120	4
Theory of Operation	6
Pumping	6
Specifications	7
Installation	8
Maintenance	10
Troubleshooting	12
Repair	
Fluidizing Tube Replacement	15
Pump Disassembly	16
Pump Assembly	18
Pinch Valve Removal	20
Pinch Valve Replacement	20
Pinch Valve Installation	21
Tubing Diagrams	22
Parts	27



Contact us

VERNE TECHNOLOGY welcomes requests for information, comments, and inquiries about its products. General information about VERNE TECHNOLOGY can be found on the Internet using the following address: <http://www.vernetechnology.it>.

Note

This is a VERNE TECHNOLOGY publication which is protected by copyright. Original copyright date 2016. No part of this document may be photocopied, reproduced, or translated to another language without the prior written consent of VERNE TECHNOLOGY. The information contained in this publication is subject to change without notice.

Safety

Read and follow these safety instructions. Task-and equipment-specific warnings, cautions, and instructions are included in equipment documentation where appropriate.

Make sure all equipment documentation, including these instructions, is accessible to all persons operating or servicing equipment.

Qualified Personnel

Equipment owners are responsible for making sure that Vere Technology equipment is installed, operated, and serviced by qualified personnel. Qualified personnel are those employees or contractors who are trained to safely perform their assigned tasks. They are familiar with all relevant safety rules and regulations and are physically capable of performing their assigned tasks.

Intended Use

Use of NEA 120 equipment in ways other than those described in the documentation supplied with the equipment may result in injury to persons or damage to property.

Some examples of unintended use of equipment include

- using incompatible materials
- making unauthorized modifications
- removing or bypassing safety guards or interlocks
- using incompatible or damaged parts
- using unapproved auxiliary equipment
- operating equipment in excess of maximum ratings

Regulations and Approvals

Make sure all equipment is rated and approved for the environment in which it is used. Any approvals obtained for Vere Technology equipment will be voided if instructions for installation, operation, and service are not followed.

All phases of equipment installation must comply with all federal, state, and local codes.

Personal Safety

To prevent injury follow these instructions.

- Do not operate or service equipment unless you are qualified.
- Do not operate equipment unless safety guards, doors, or covers are intact and automatic interlocks are operating properly. Do not bypass or disarm any safety devices.
- Keep clear of moving equipment. Before adjusting or servicing any moving equipment, shut off the power supply and wait until the equipment comes to a complete stop. Lock out power and secure the equipment to prevent unexpected movement.
- Relieve (bleed off) hydraulic and pneumatic pressure before adjusting or servicing pressurized systems or components. Disconnect, lock out, and tag switches before servicing electrical equipment.
- Obtain and read Material Safety Data Sheets (MSDS) for all materials used. Follow the manufacturer's instructions for safe handling and use of materials, and use recommended personal protection device
- Grounding inside and around the booth openings must comply with NFPA requirements for Class 2, Division 1 or 2 Hazardous Locations. Refer to NFPA 33, NFPA 70 (NEC articles 500, 502, and 516), and NFPA 77, latest conditions.
- To prevent injury, be aware of less-obvious dangers in the workplace that often cannot be completely eliminated, such as hot surfaces, sharp edges, energized electrical circuits, and moving parts that cannot be enclosed or otherwise guarded for practical reasons.

Fire Safety

To avoid a fire or explosion, follow these instructions.

- Do not smoke, weld, grind, or use open flames where flammable materials are being used or stored.
- Provide adequate ventilation to prevent dangerous concentrations of volatile materials or vapors. Refer to local codes or your material MSDS for guidance.
- Do not disconnect live electrical circuits while working with flammable materials. Shut off power at a disconnect switch first to prevent sparking.
- Know where emergency stop buttons, shutoff valves, and fire extinguishers are located. If a fire starts in a spray booth, immediately shut off the spray system and exhaust fans.
- Clean, maintain, test, and repair equipment according to the instructions in your equipment documentation.
- Use only replacement parts that are designed for use with original equipment. Contact your Vere Technology representative for parts information and advice.

Grounding



WARNING: Operating faulty electrostatic equipment is hazardous and can cause electrocution, fire, or explosion. Make resistance checks part of your periodic maintenance program. If you receive even a slight electrical shock or notice static sparking or arcing, shut down all electrical or electrostatic equipment immediately. Do not restart the equipment until the problem has been identified and corrected

- All electrically conductive objects in the spray areas shall be electrically connected to ground with a resistance of not more than 1 megohm as measured with an instrument that applies at least 500 volts to the circuit being evaluated.
- Equipment to be grounded includes, but is not limited to, the floor of the spray area, operator platforms, hoppers, photoeye supports, and blow-off nozzles. Personnel working in the spray area must be grounded.
- There is a possible ignition potential from the charged human body. Personnel standing on a painted surface, such as an operator platform, or wearing non-conductive shoes, are not grounded. Personnel must wear shoes with conductive soles or use a ground strap to maintain a connection to ground when working with or around electrostatic equipment.
- Operators must maintain skin-to-handle contact between their hand and the gun handle to prevent shocks while operating manual electrostatic spray guns. If gloves must be worn, cut away the palm or fingers, wear electrically conductive gloves, or wear a grounding strap connected to the gun handle or other true earth ground.
- Shut off electrostatic power supplies and ground gun electrodes before making adjustments or cleaning powder spray guns.
- Connect all disconnected equipment, ground cables, and wires after servicing equipment.

NEA 120 peristaltic dense pump

3

Action in the Event of a Malfunction

If a system or any equipment in a system malfunctions, shut off the system immediately and perform the following steps:

- Disconnect and lock out electrical power. Close pneumatic shutoff valves and relieve pressures
- Identify the reason for the malfunction and correct it before restarting the equipment.

Disposal

Dispose of equipment and materials used in operation and servicing according to local codes.

Description

See Figure 1

The NEA 120 (peristaltic dense pump) powder pump transports large amounts of powder from one location to another.

The pump design and the small diameter suction and delivery tubing used with the pump allow it to be purged quickly and thoroughly.

The pump is more efficient than traditional venturi-style pumps in that very little of the air that is used to operate the pump is mixed into the powder stream. Only the air that is used to move the powder out of the pump and into the delivery tubing enters the powder stream.

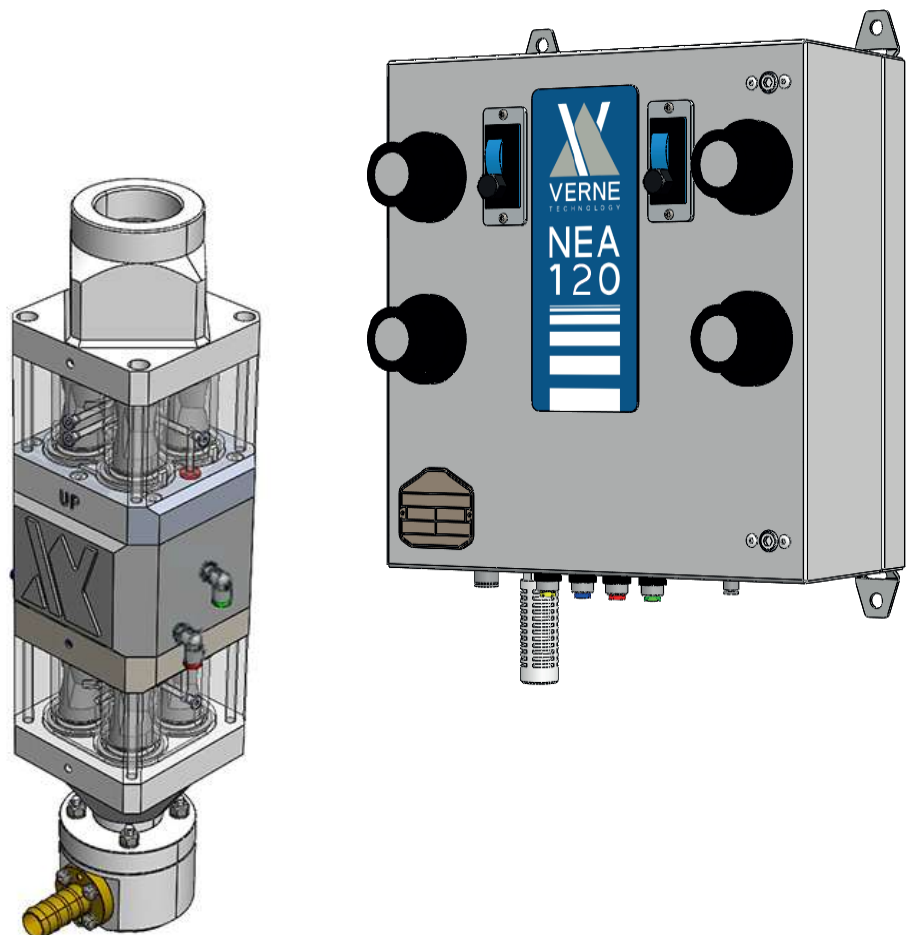

Figure 1
peristaltic dense pump

NEA 120 peristaltic dense pump

4

peristaltic dense pump components NEA 120

See figure 2.

n° Item	Description	Function
Air control components		
01 - 02	Timer T0.5 (01 left - 02 right)	Check the operating sequences of the following components: valves activation cycle control, valves control fluid tubes and valve control sleeve valves
03	Regulator and pressure gauge (SUPPLY)	Adjust the closing pressure Max 0.6 Mpa (6 bar)
04	Regulator and pressure gauge (VACUUM)	Adjust the closing pressure Max 0.48 Mpa (4.8 bar)
05	Regulator and pressure gauge (PINCH VALVES)	Adjust the closing pressure of the sleeve valves to 0:24 to 0:27 Mpa (2.7-3.0 bar).
06	Regulator and pressure gauge (TRANSPORT)	Adjust the transport of the product pressure. Usually set to from 0.15 to 0.25 Mpa (1.5-2.5 bar).
A	PV 1 : management valve cycle NEA PUMP	cycle NEA PUMP
B	PV 2: management valve pinch valve	pinch valves
C	VACUUM GENERATOR	
D	PV 3: management valve tubes	management valve - tubes
E	Silencer	It allows silent operating an air outlet of the pump.

NEA 120 peristaltic dense pump

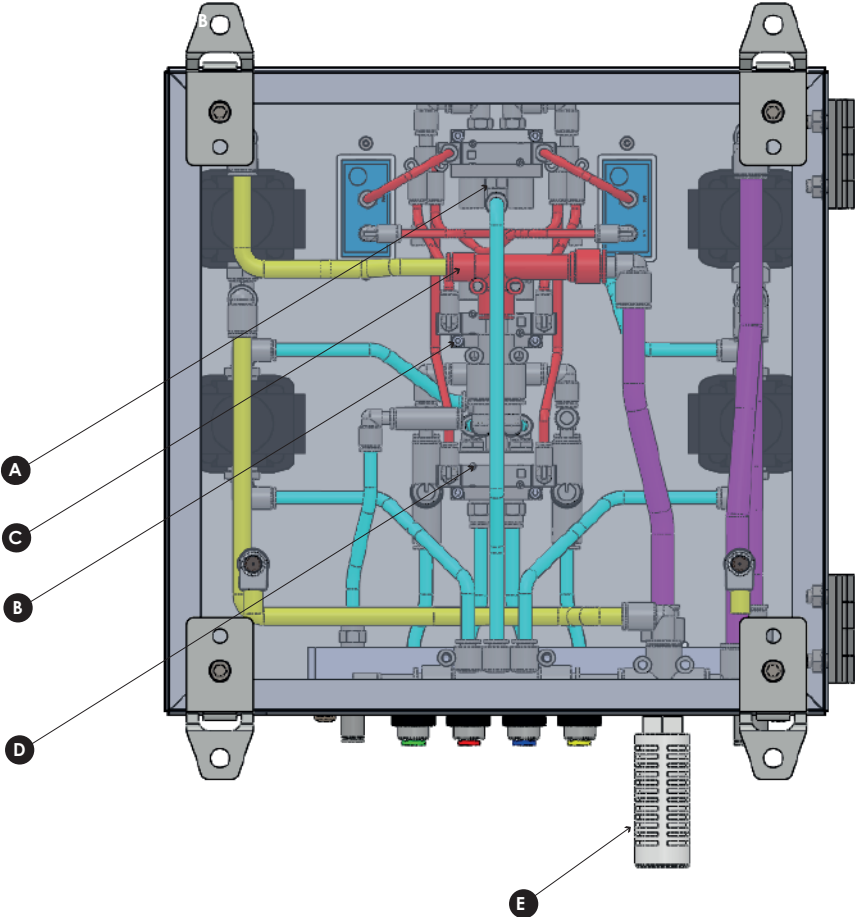
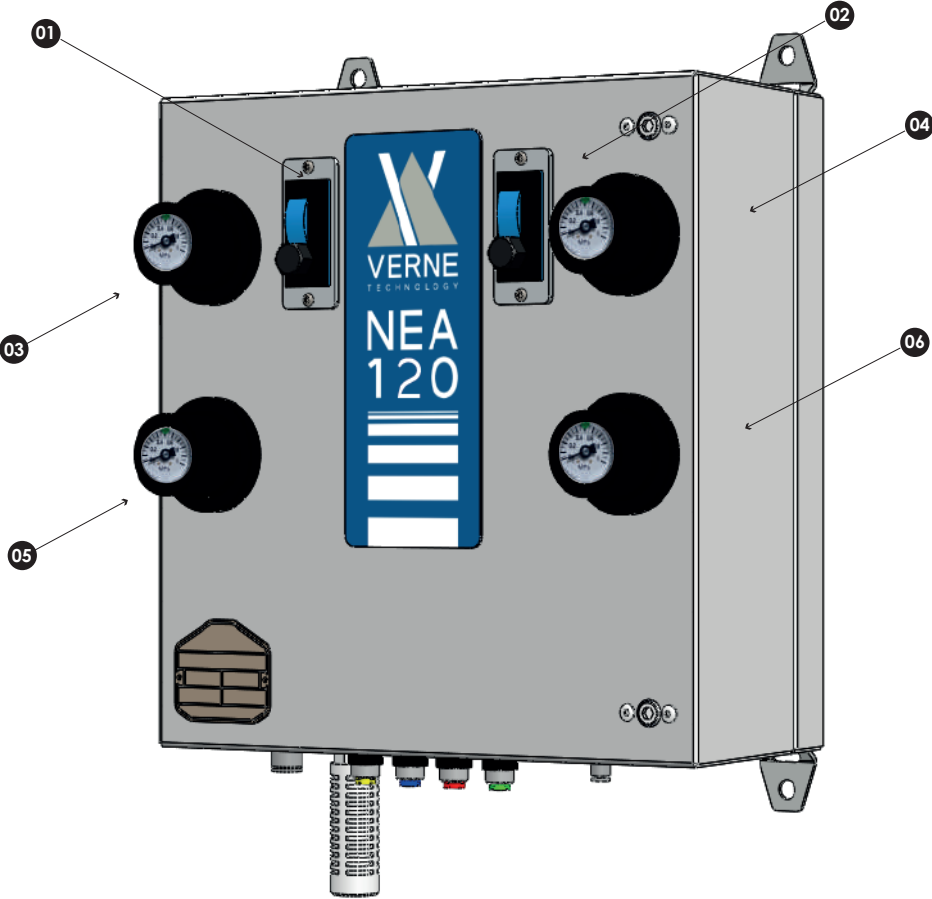

Figure 2
Box Components
(Internal, cover removal)

NEA 120 peristaltic dense pump

Principle of operation

Pumping

The pump NEA 120 is composed of four tanks that alternate in a continuous cycle 2+2 stroke collection and transport of the powder.

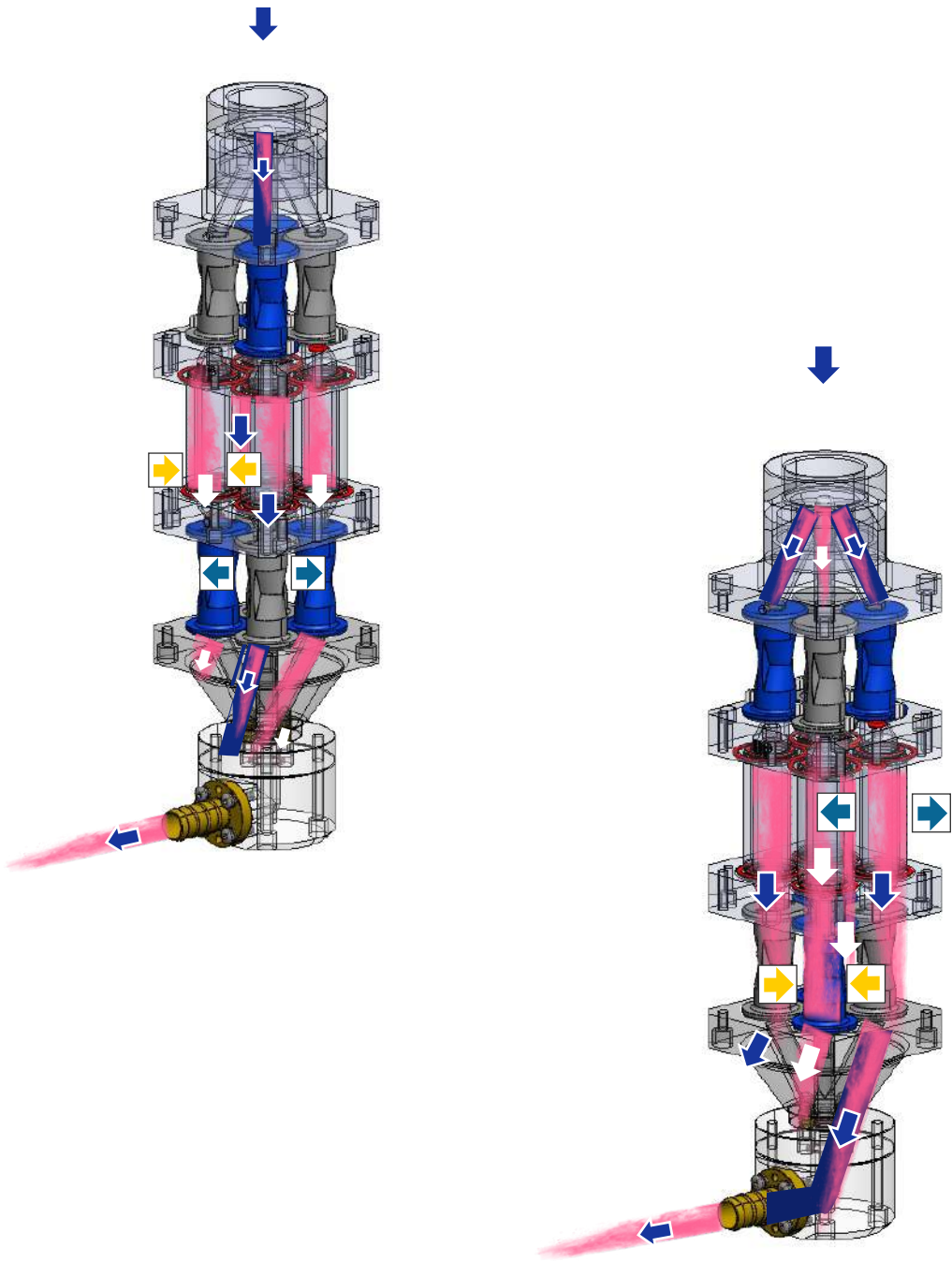

Figure 3
Operating principle - Pumping

◀ ▶ Vacuum ▶ ◀ Pressure ■ OPEN ■ CLOSED

Bleeding



The purging process depends on the type of integration of the pump in the powder system line.

Keep the pump OFF, THROUGH A 1" PNEUMATIC VALVE CONNECTED TO A COMPRESSED AIR TANK start the cycle purge by introducing several pulses of air pressure FROM THE END OF THE TRANSPORT HOSE IN THE DIRECTION OF THE PUMP BODY.

NOTE: During purging the line air pressure flows through THE TRANSPORT HOSE, PUMP BODY INLET, fluidization pipes, pinch valves UP TO THE 1" ½ THREADED TERMINAL OF THE CYCLONE CONE.

If the purge air is supplied from a supply center or from a keg dispensing system, usually it is pulsating. The pulses are usually active for 500 milliseconds and deactivated for a few seconds.

If purging is started manually by pressing the purge button on a manual pump station, air purge is not pulsed. The purge button must be pressed repeatedly to pulse air.

If the bleeding is started manually by pressing the purge button on a station manual pump, the bleed air is not pulsed. The purge button is pressed repeatedly to supply air pulse.

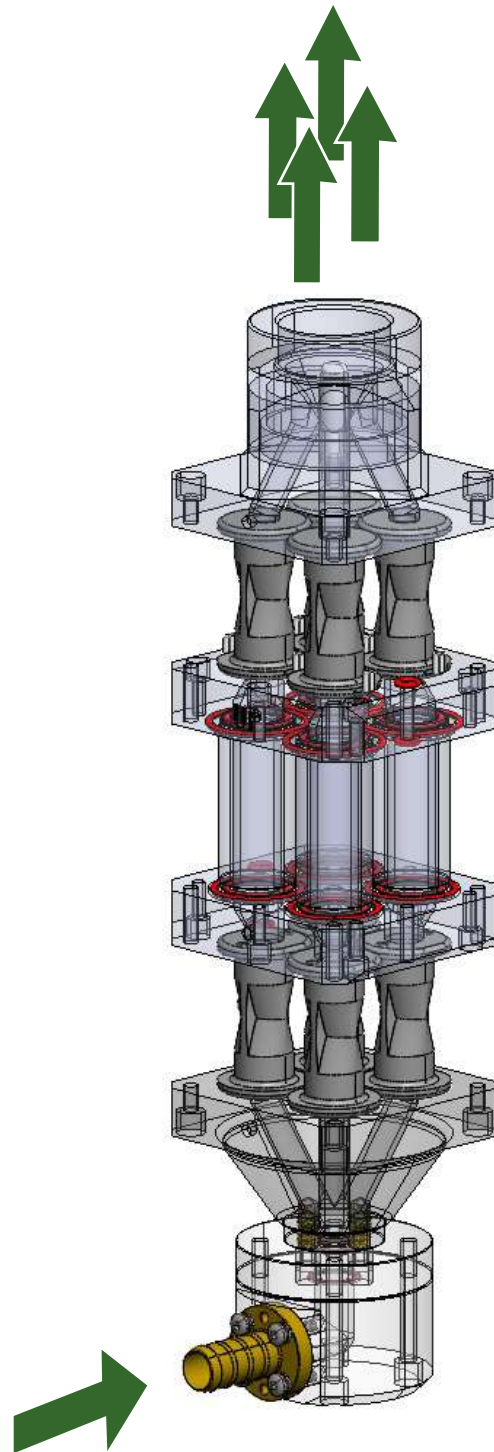
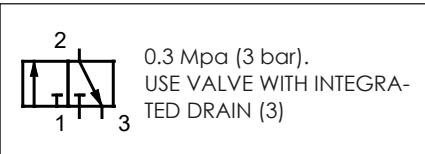
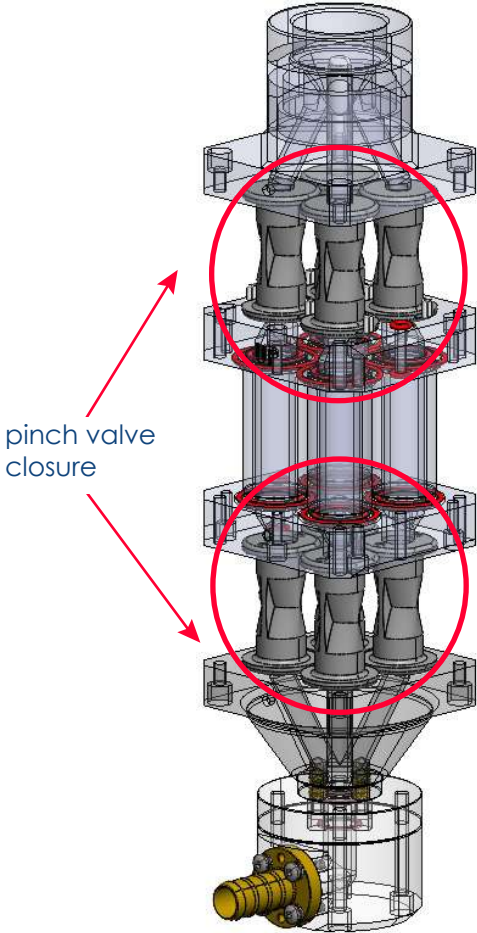
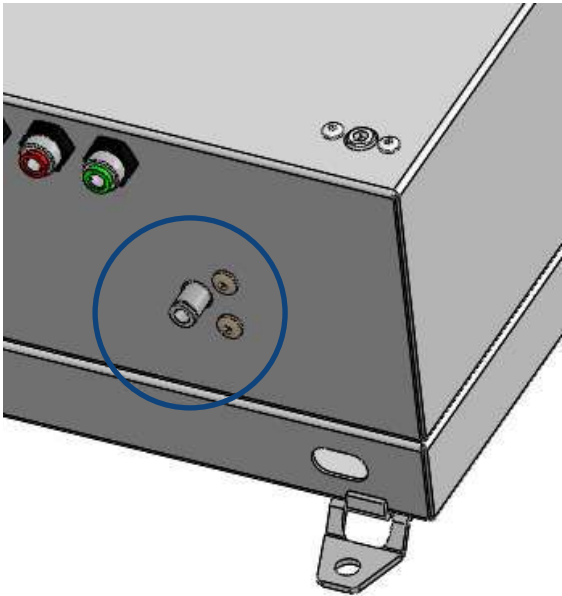
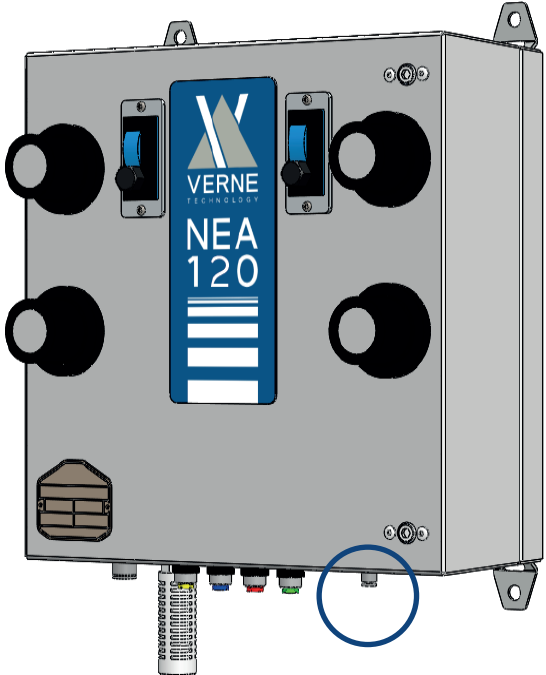

Figure 3
Operating principle - cleaning

NEA 120 peristaltic dense pump

OPTION: CLOSING PINCH VALVES

All pinch valves will close



 **WARNING** Before activating the option: Pinch valves closed, check that the pump is off.

Figure 3
Operating principle - cleaning

NEA 120 peristaltic dense pump

Technical data

Flow rate (max)	UP TO: 100 kg/h
General Supply pressure (min.)	0.6 Mpa (6 bar)
General Supply pressure (max.)	0.8 Mpa (8 bar)
Regulator supply - working pressure	0.6 Mpa (6 bar)
Regulator Pinch valve - working pressure	0.27 - 0.30 Mpa (2,7 -3,0 bar)
Regulator Vacuum - working pressure	100% - 0.48 Mpa (4,8 bar) to reduce the flow rate, decrease the pressure
Regulator Transport - working pressure	0.15 - 0.25 Mpa
Total air consumption	400l /min
Filtered compressed air with the following properties	
Permissible humidity: 95% non-condensing	
Operating ambient temperature from +15 to +40	
Claening	Min 6 Bar - Max 8 Bar
Transporte tube	POLYETHYLENE : D. INT. 16 mm (LONG MAX 20 m) ANTISTATIC : D. INT. 16 mm (LONG MAX 20 m) BEST RESULT OBTAINABLE USING THE SHORTEST POSSIBLE HOSE
Weight/dimensions	Kg 13 pump+control panel - See figure 5

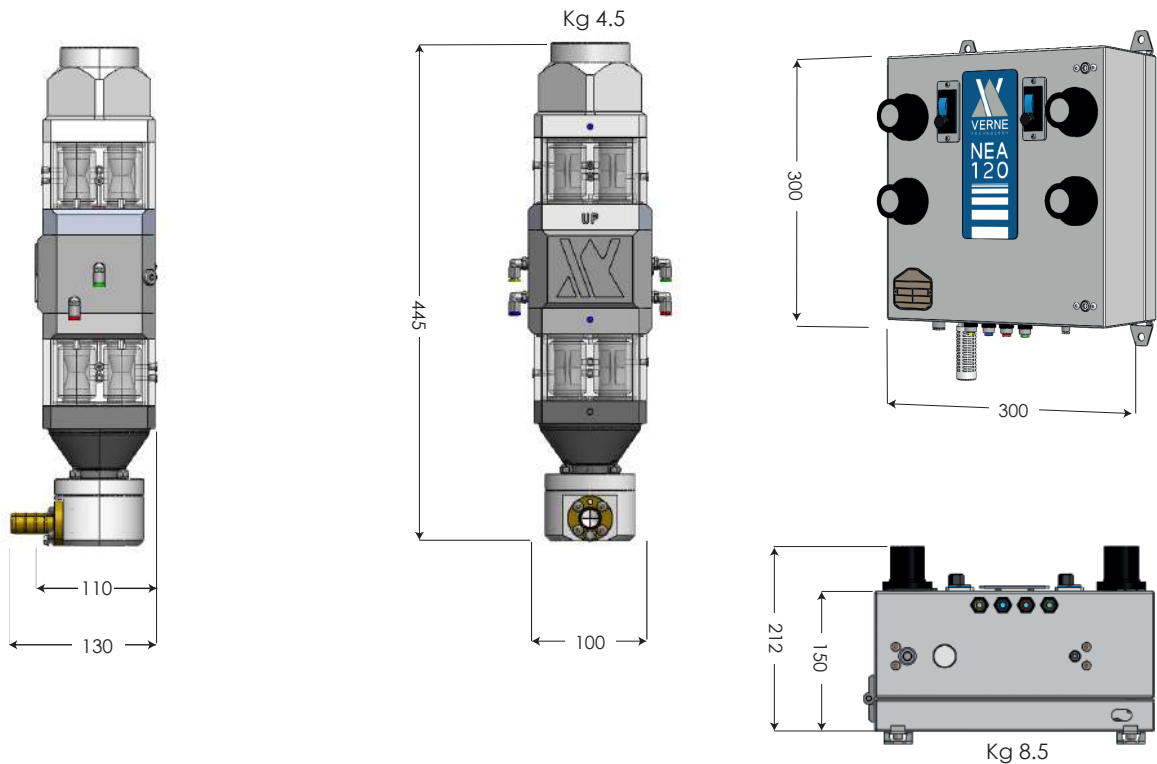

Figure 5 Pump dimensions

Installation



WARNING: The pump must be securely connected to a true earth ground. Failure to ground the pump could result in a fire or explosion.

NOTE: The pump is normally mounted on a panel that includes an operating air regulator, and a manual pushbutton and piloted-operated air valve for manual purging. The panel may also include an auxiliary regulator for fluidizing the powder source.

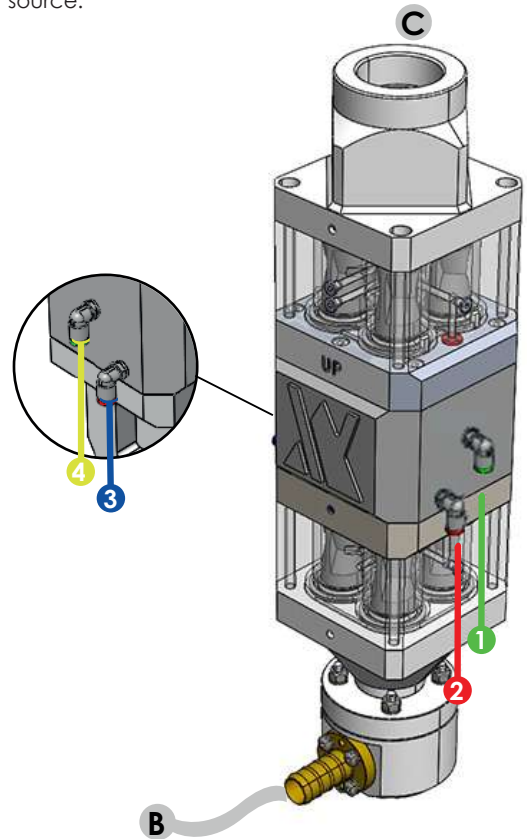
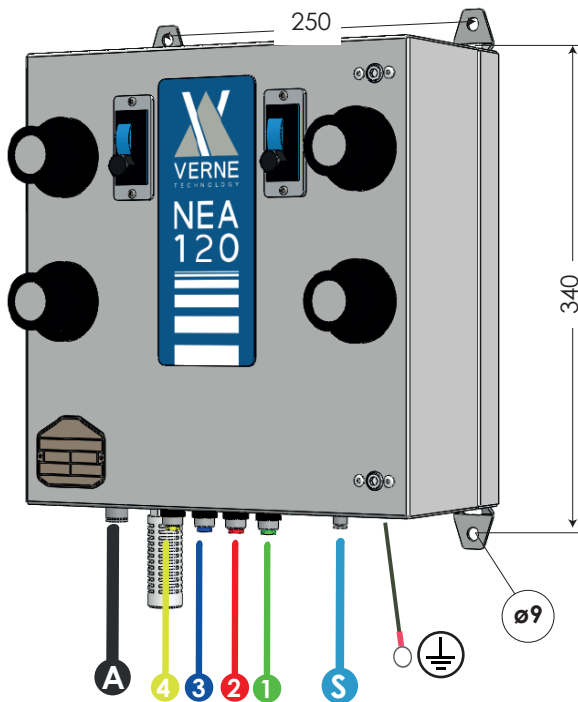

Panel Mounting Dimensions

Use the supplied M6 screws, washers, and nuts to mount the pump.

NOTE: Included are 4 mounting holes and 1 set of $\varnothing 9$ fasteners. Use the six mounting holes that best match your mounting surface.

Tubing Connections

NOTE: For best results, keep the powder suction and delivery tubing as short as possible.

CONNECTION	TYPE	FUNCTION
A	10 mm blue polyurethane tubing	From customer-supplied purge air source 7 bar (0.7 Mpa) max.
B	POLYETHYLENE : \varnothing INT. 16 mm (LONG MAX 20m) ANTISTATIC : \varnothing INT. 16 mm (LONG MAX 20m)	To powder destination
C		From powder source
S	POLIURETANE : \varnothing Ext. 6 \varnothing Int. 4 mm	
1	POLIURETANE : \varnothing Ext. 6 \varnothing Int. 4 mm (GREEN - LONG MAX 3m)	
2	POLIURETANE : \varnothing Ext. 6 \varnothing Int. 4 mm (RED - LONG MAX 3m)	
3	POLIURETANE : \varnothing Ext. 6 \varnothing Int. 4 mm (BLUE - LONG MAX 3m)	
4	POLIURETANE : \varnothing Ext. 6 \varnothing Int. 4 mm (YELLOW - LONG MAX 3m)	
	Pump ground wire	To earth ground

NEA 120 peristaltic dense pump

Operation

See figure 8.

- To start the pump turn on the air supply operation (min 0.6 Mpa (6 bar). Set the regulator SUPPLY at 0.6Mpa (6 bar).
- Set the regulator TRANSPORT
- Set the regulator PINCH VALVES
- Set the regulator VACUUM

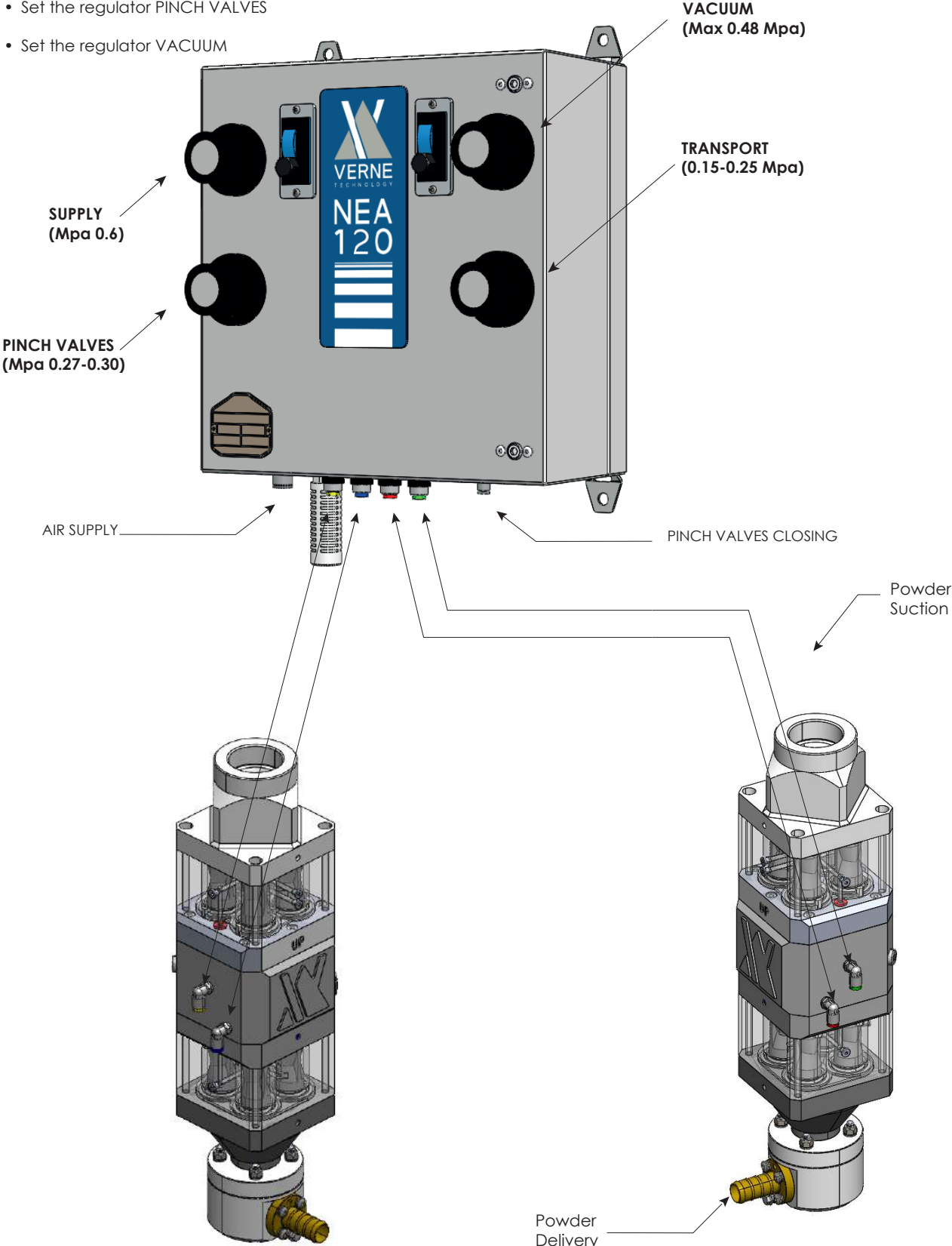

Installation of the system

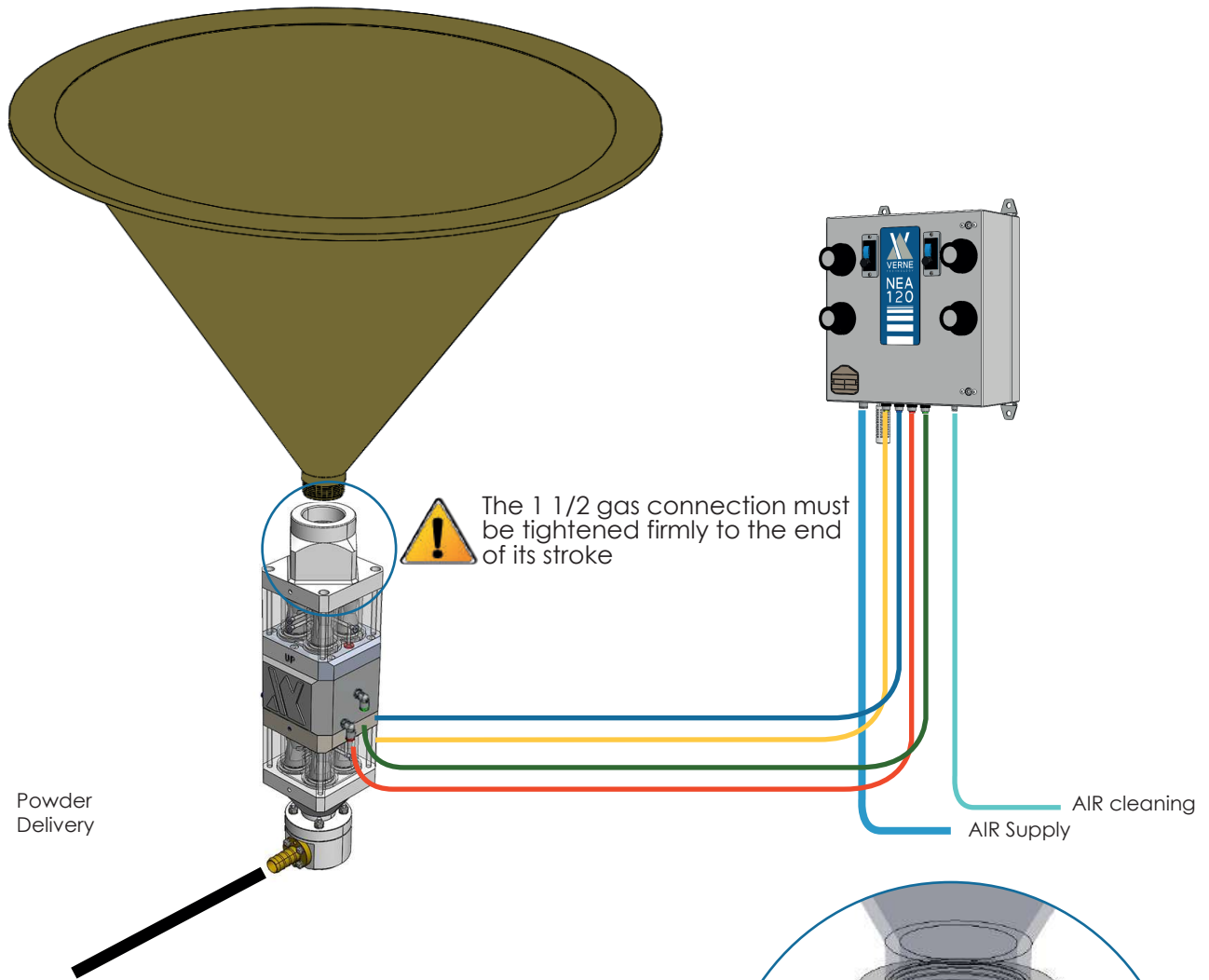

Powder outlet flow orientation

it is possible to direct the powder outlet by simply unscrewing the 4 M6 screws of the PN.....
At this point, rotate the pump in the preferred direction and retighten the 4 screws supplied

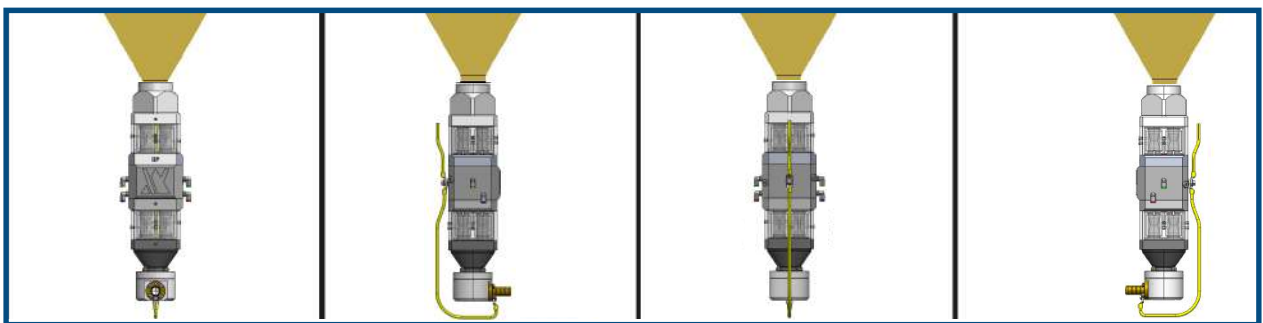
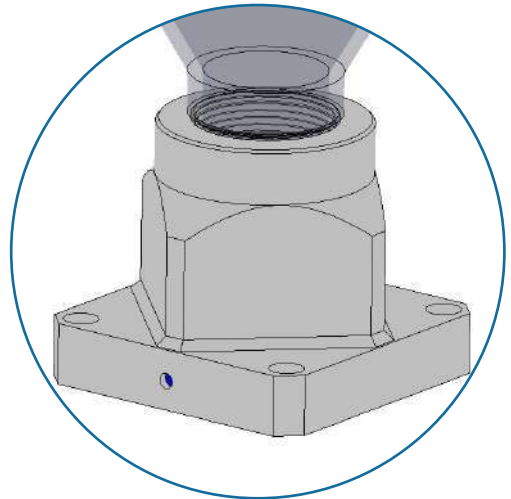



Maintenance

Perform these maintenance procedures to keep your pump operating at peak efficiency.

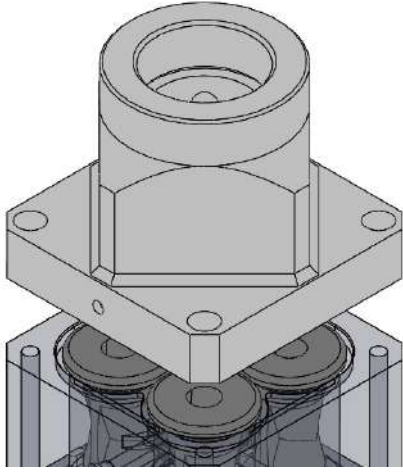

WARNING: Allow only qualified personnel to perform the following tasks. Follow the safety instructions in this document and all other related documentation.

NOTA: You may have to perform these procedures more or less frequently, depending on factors such as operator experience and type of powder used.

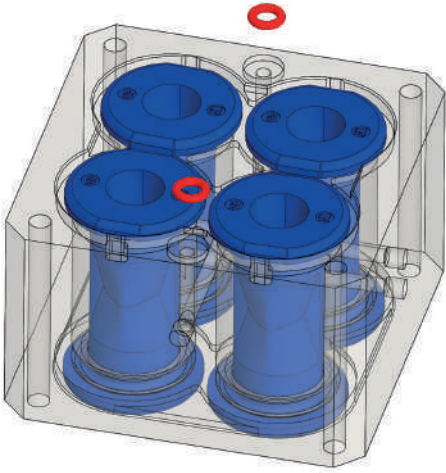
Frequency	P/N	Procedure
<p>Every four Months or Each Time You Disassemble the Pump</p>	 <p>P/N 10086</p>	<p>Remove the INLET BODY from the assembly pump and check if you show signs of wear or sintering. If necessary, clean these components with an apparatus for ultrasonic cleaning</p>
<p>Daily</p> <p> Perform maintenance on both NORD+SOUTH components</p>	 <p>P/N 10005-XX</p>	<p>Inspect the PINCH VALVES BODY for signs of powder leakage. If you see powder in the pinch valve body or stress cracks in the pinch valves, replace the pinch valves.</p>

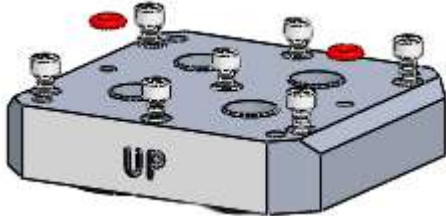
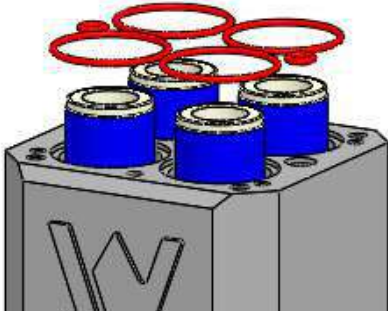
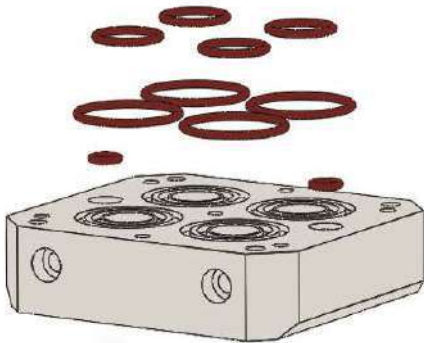
Frequency	P/N	Procedure
<p>Every four Months or Each Time You Disassemble the Pump</p>	 <p>P/N 10087</p>	<p>Remove the body from the assembly INTERMEDIATE BODY pump and check if you show signs of wear or sintering. If necessary, clean these components with an apparatus for ultrasonic cleaning.</p>
<p>Every four Months or Each Time You Disassemble the Pump</p>	 <p>P/N 10135</p>	<p>Remove the fluidizing tubes and check structural conformity. In case of defects or damage, replace the pipes.</p>
<p>Every four Months or Each Time You Disassemble the Pump</p>	 <p>P/N 10117</p>	<p>Remove the body from the assembly INTERMEDIATE BODY pump and check if you show signs of wear or sintering. If necessary, clean these components with an apparatus for ultrasonic cleaning.</p>

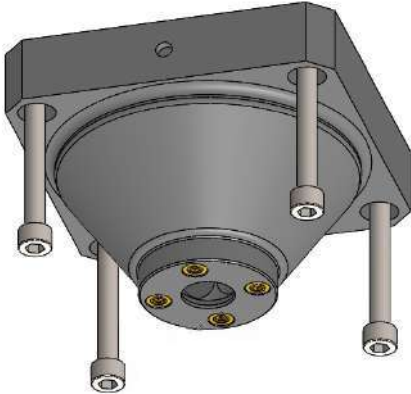
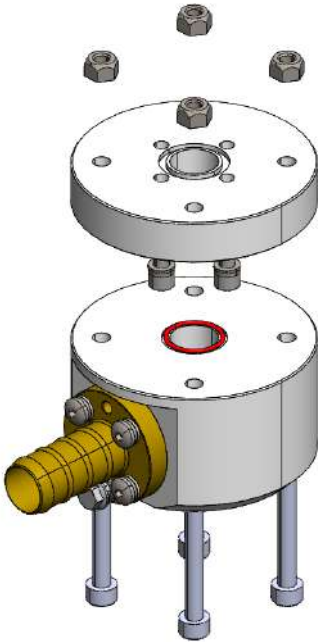
Frequency	P/N	Procedure
<p>Every four Months or Each Time You Disassemble the Pump</p>	 <p>P/N 10084</p>	<p>Remove the INLET-OUTLET BODY from the assembly pump and check if you show signs of wear or sintering. If necessary, clean these components with an apparatus for ultrasonic cleaning</p>
<p>Every four Months or Each Time You Disassemble the Pump</p>	 <p>P/N 10137</p>	<p>Remove the TERMINAL 90° OUTLET from the assembly pump and check if you show signs of wear or sintering. If necessary, clean these components with an apparatus for ultrasonic cleaning</p>

Diagnostics

Problem	Possible cause	Corrective action
1. Reduced powder output from the conveying tube (The pinch valves open and close)	<i>Blockage in INLET BODY Air transport set too high</i>	Check the Transport INLET BODY for blockages. Remove the INLET BODY and purge with compressed air.
	<i>Carrier air set too high</i>	Decrease air pressure transport.
	<i>Carrier air set too low</i>	Increasing the air pressure transport.
	<i>Dust extraction set</i>	Decrease the Vacuum pressure (Max 0.48 Mpa).
	<i>Dust extraction set</i>	Increase the Vacuum pressure (Max 0.48 Mpa).
	<i>Pinch valve defective or damaged</i>	Replace the pinch valves
	<i>Fluidizing tubes defective or damaged</i>	Replace the fluidizing tubes
	<i>PV3 carrier air valve not working</i>	<p>See Pipe Diagrams. Turn off the pump and unplug the pipes connected to the pump body. Turn on the pump and check if i pipes exhibit pressure alternation of positive and negative air. regulator/pressure gauge: Transport Reg. + Vacuum Reg. If there is no pressure, replace the valve.</p> <p>If the valve works, but you can't hear it positive or negative air pressure in the pipes, check if they are blockages in the air lines that They go in and out of the valve.</p>

Diagnostics

Problem	Possible cause	Corrective action
2. Reduced powder output from the conveying tube (the pinch valves DO NOT open and close)	<i>Pinch valve defective or damaged</i>	Replace the pinch valves
	<i>PV 1 valve transport cycle activation not working</i>	See Pipe Diagrams. If the valve works, but you can't hear it positive pressure from outlets 2 4, check pressure regulator/gauge (Reg. Supply). Turn off the pump and unplug the valve feed tube. Turn on the pump and check that there is positive pressure at 0.6 Mpa. If there is pressure, replace the valve.
	<i>Supply pressure No valve PV1</i>	See Pipe Diagrams. Turn off the pump and unplug the valve feed tube. Turn on the pump and check that there is pressure positive. If there is no pressure, replace the regulator with pressure gauge (Reg. Supply).
	<i>Pinch Valves cycle activation PV 2 valve not working</i>	See Pipe Diagrams. If the valve works, but you can't hear it positive pressure from outlets 2 4, check pressure regulator/pressure gauge (Reg. Pinch Valves). Turn off the pump and unplug the pipes connected to the pump body. Turn on the pump and check if i pipes exhibit pressure alternation positive. If there is no pressure, replace the valve.
	<i>Supply pressure PV2 valve absent</i>	See Pipe Diagrams. Turn off the pump and unplug the valve feed tube. Turn on the pump and check that there is pressure positive. If there is no pressure, replace the regulator with pressure gauge (Reg. Pinch Valves)
	<i>TIMER (RIGHT) Does not respect times</i>	See Pipe Diagrams. Turn off the pump and unplug the tube from the outlet (2) of the timer. Turn on the pump and check if pressure comes out alternately. Check for correct operation of the display and the respect of the time PRE-SET. If there is no pressure, replace the TIMER.
	<i>TIMER (LEFT) Does not respect times</i>	See Pipe Diagrams. Turn off the pump and unplug the tube from the outlet (2) of the timer. Turn on the pump and check if pressure comes out alternately. Check for correct operation of the display and the respect of the time PRE-SET. If there is no pressure, replace the TIMER.

Diagnostics

Problem	Possible cause	Corrective action
3. Low dust entry (loss of suction from the source of dust)	<i>Blockage in the powder collection tube</i>	Check if the tube has blocks. Remove the tube and purge with compressed air.
	<i>Vacuum leak from the vacuum generators</i>	Check if the vacuum generators are contaminated. In case of contamination or wear, replace both vacuum generators. Check the exhaust silencers. If the exhaust silencers turn out clogged, replace them.
	<i>O rings damaged along the way dust</i>	Check all o-rings in the path dust. Replace damaged o rings or worn out.
	<i>Clogged fluidization pipes</i>	Replace the fluidizing tubes.
4. Pinch valves that they go bad quickly, with cracks around the flange	<i>The powder tribo loads into the pump</i>	Install Valve Kit P/n 10034 a black sleeve - NOT CONDUCTIVE. Check that the device is properly grounded.

Repair



WARNING: Allow only qualified personnel to perform the following tasks. Follow the safety instructions in this document and all other related documentation.



WARNING: Shut off and relieve system air pressure before performing the following tasks. Failure to relieve air pressure may result in personal injury.

Fluidizing Tube Replacement

NOTE: In the fluidization tube kits I am including four O-rings. Replace O-rings if they are worn. It is not necessary to replace the o-ring every time you replace the fluidizing tubes.

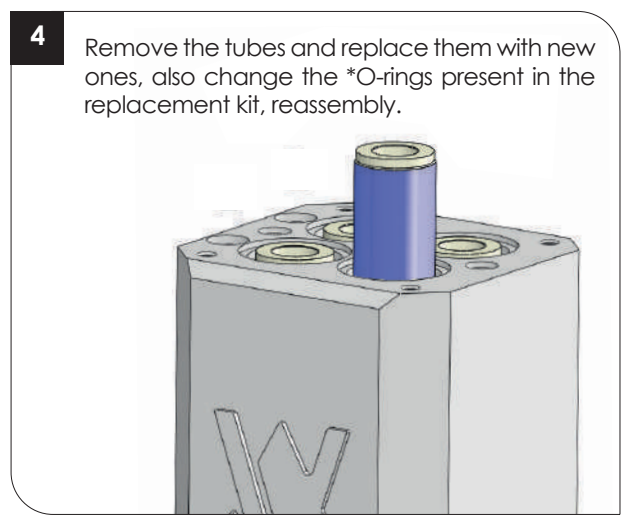
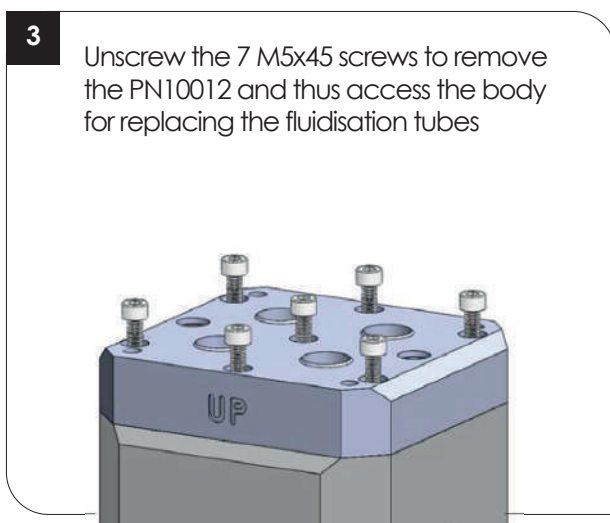
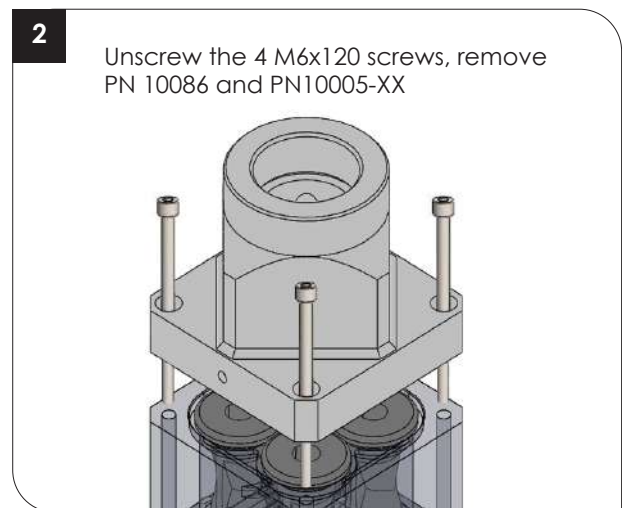
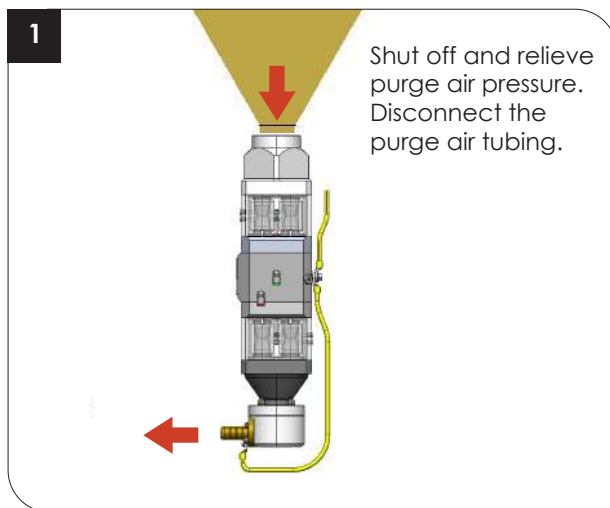

*In the fluidization tube kits, there are included O-rings. Replace O-rings if they are worn.

Pump Disassembly



WARNING: Shut off and relieve system air pressure before performing the following tasks. Failure to relieve air pressure may result in personal injury.

1. See figure 9. Disconnect the purge air lines from the top of the pump.
2. Disconnect the inlet and outlet powder tubing from the bottom of the pump.
3. Remove the two screws (A) from the pump.
4. See figure 9. Disconnect one end of each of the air tubes indicated.
5. See figure 10. Remove the tubes securing the pump assembly to the base.
6. See Figure 11. Starting with the fluidizing tubes, disassemble the pump as shown.

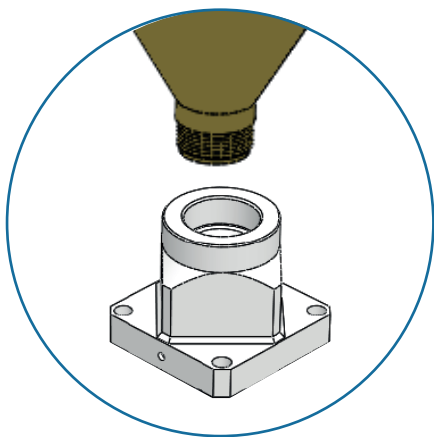

The 1 1/2 gas connection must be tightened firmly to the end of its stroke

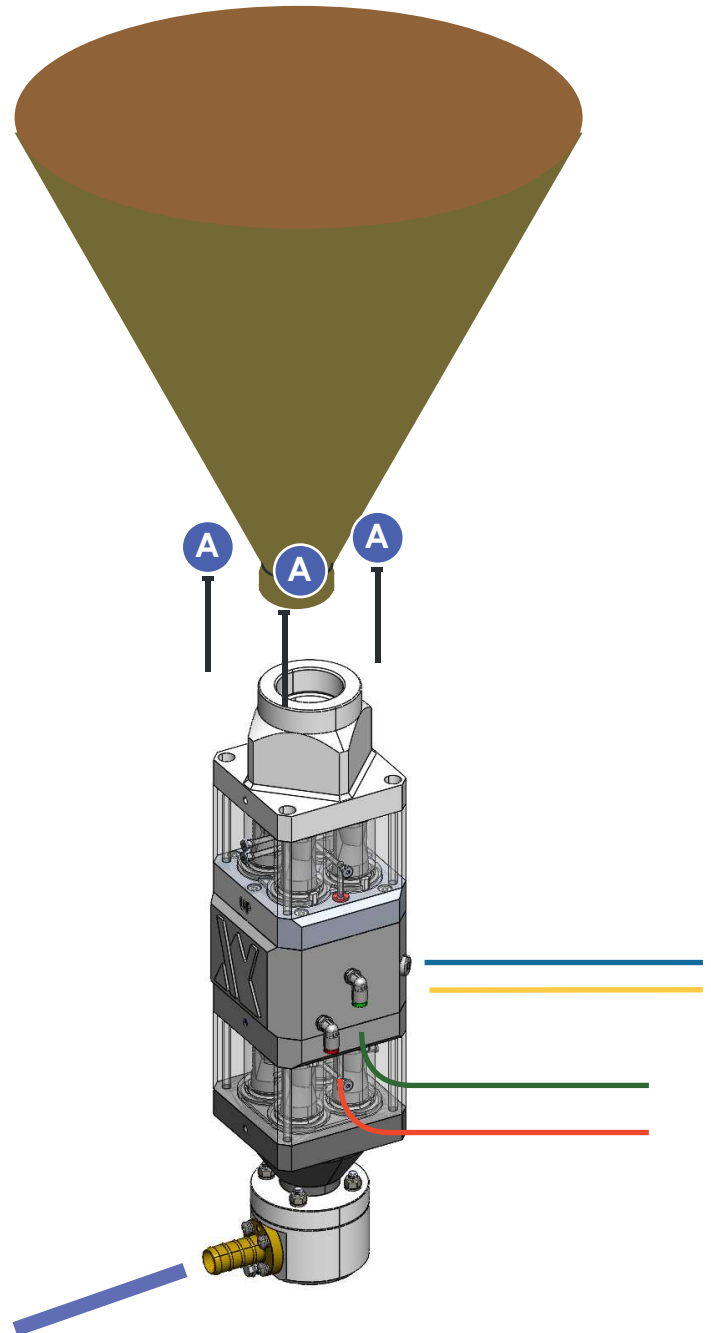

NOTE: Refer to Pinch Valve Replacement on page 21 for instructions on pulling the pinch valves out of the pinch valve body.

Figure 10

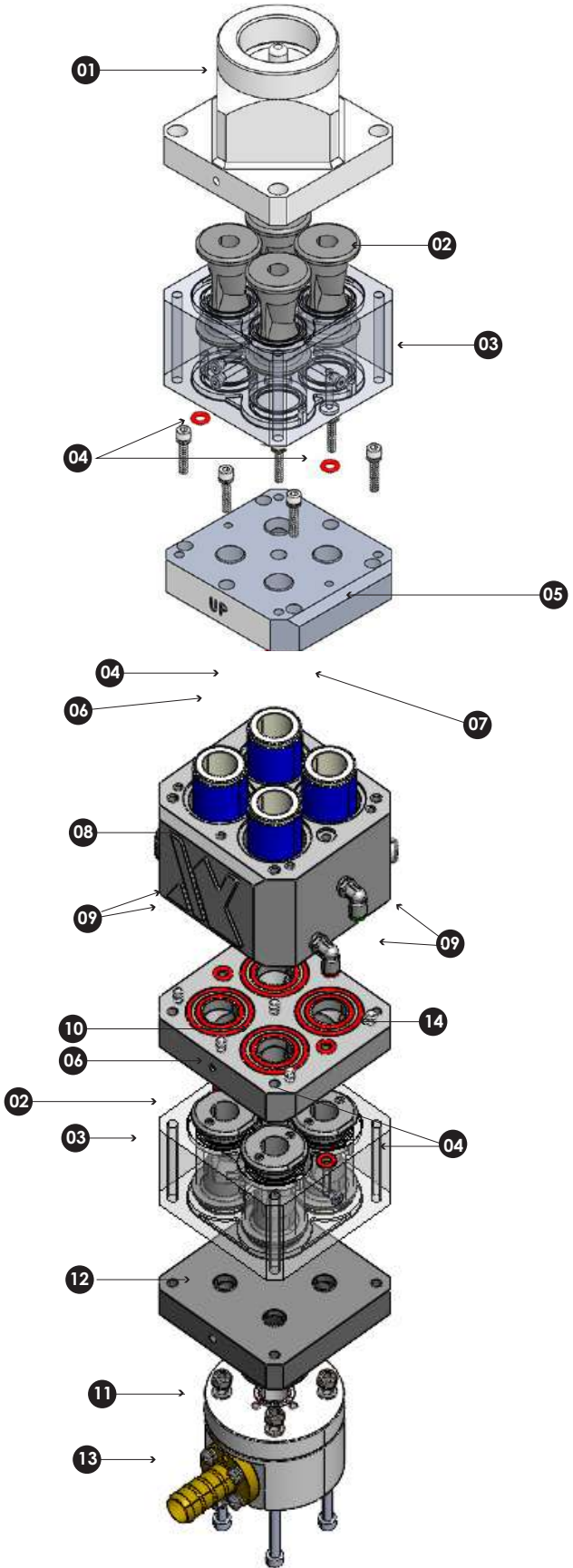

Figure 11 Pump Disassembly and Assembly

- | | | |
|-------------------------------|------------------------------|--------------------------------|
| 01. Inlet Body | 06. O-Ring Silicone 130 | 11. Terminal 90° - Outlet |
| 02. Pinch Valves | 07. O-Ring Silicone 37,6x2,4 | 12. INLET-OUTLET BODY |
| 03. Pinch Valves Body | 08. Fluidizing Tubes Body | 13. Brass adapter d.int.16mm |
| 04. O-Ring Silicone 3024 | 09. Elbow 90° G1/8"-6 | 14. Intermediate Body - Outlet |
| 05. Intermediate Body - Inlet | 10. O-Ring Silicone 3131 | |

Pump Assembly



CAUTION: Follow the assembly order and specifications shown. Pump damage may occur if you do not carefully follow the assembly instructions.

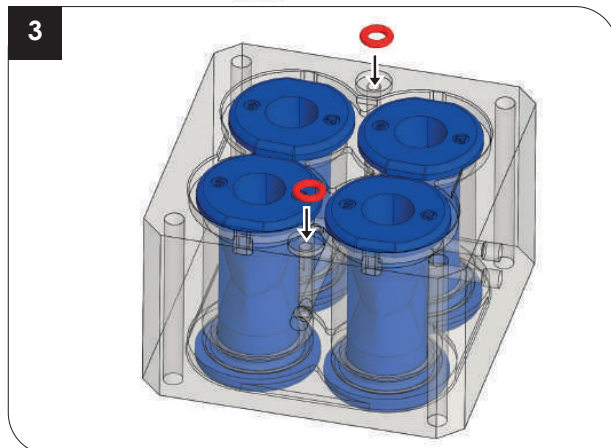
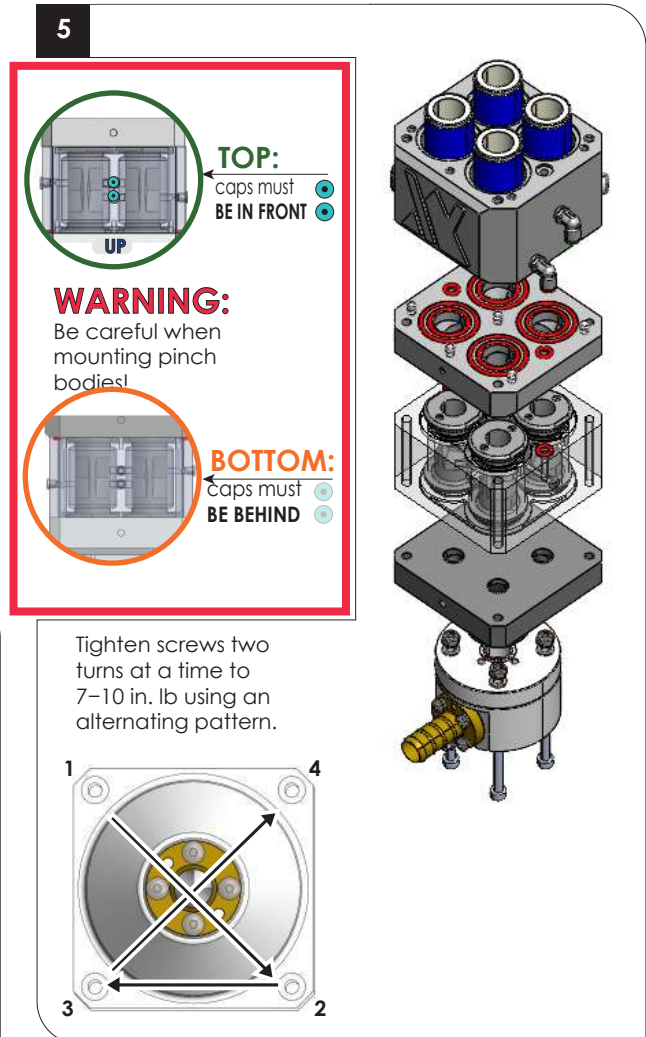
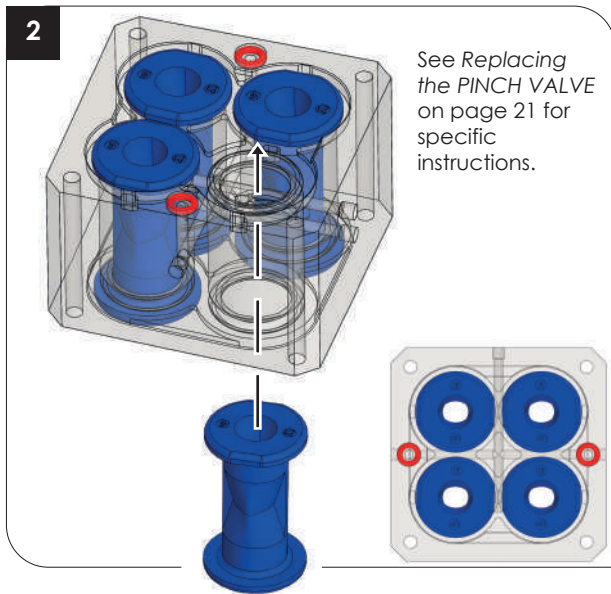
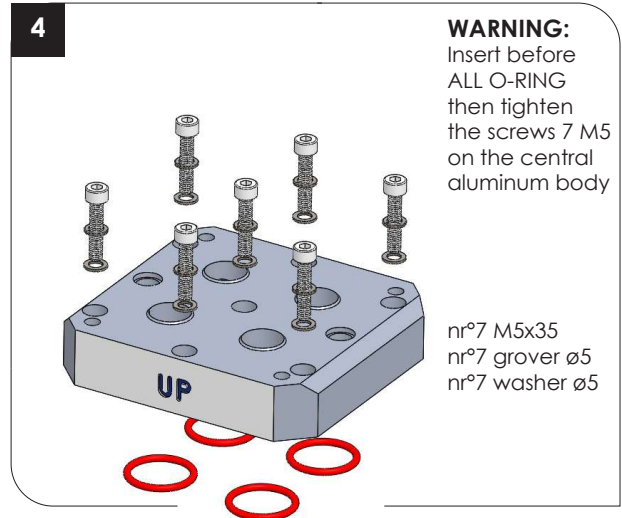
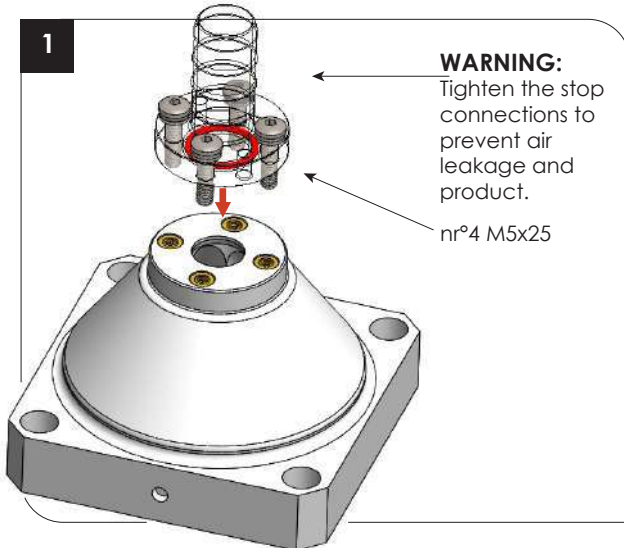

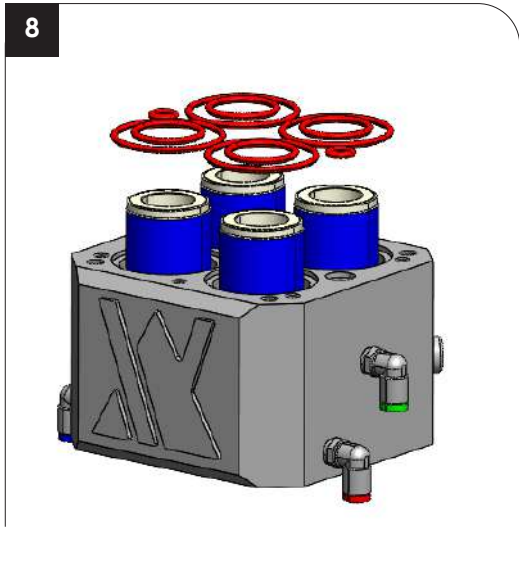
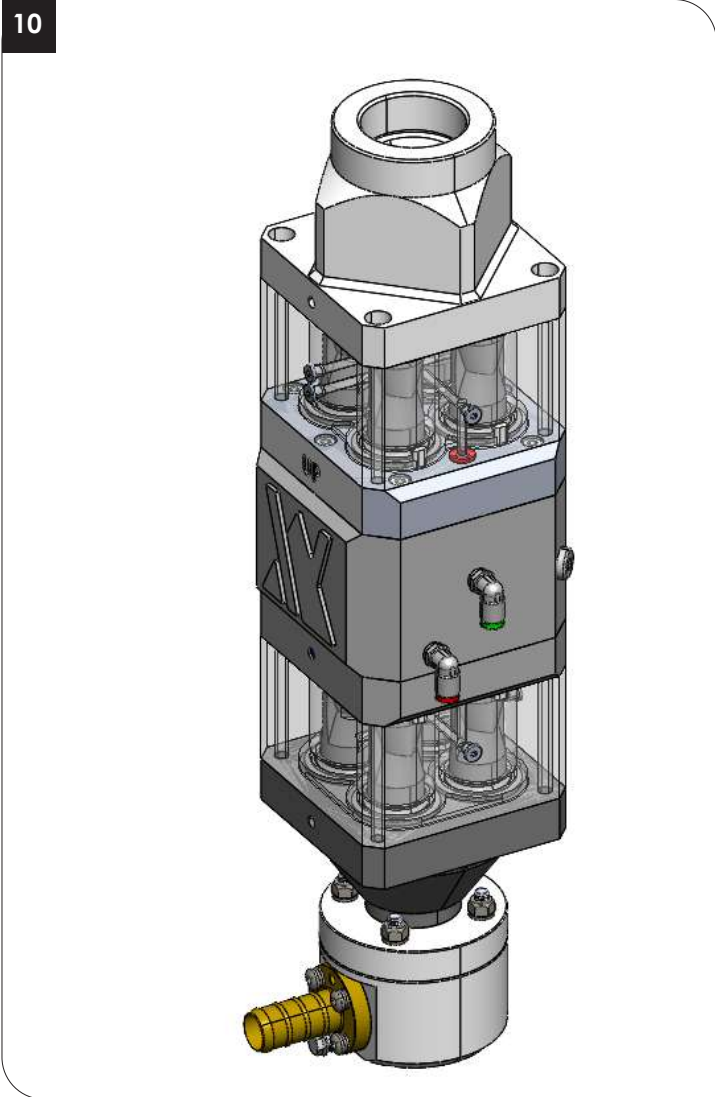
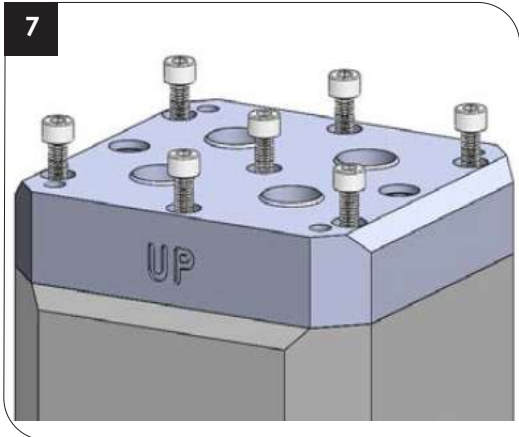
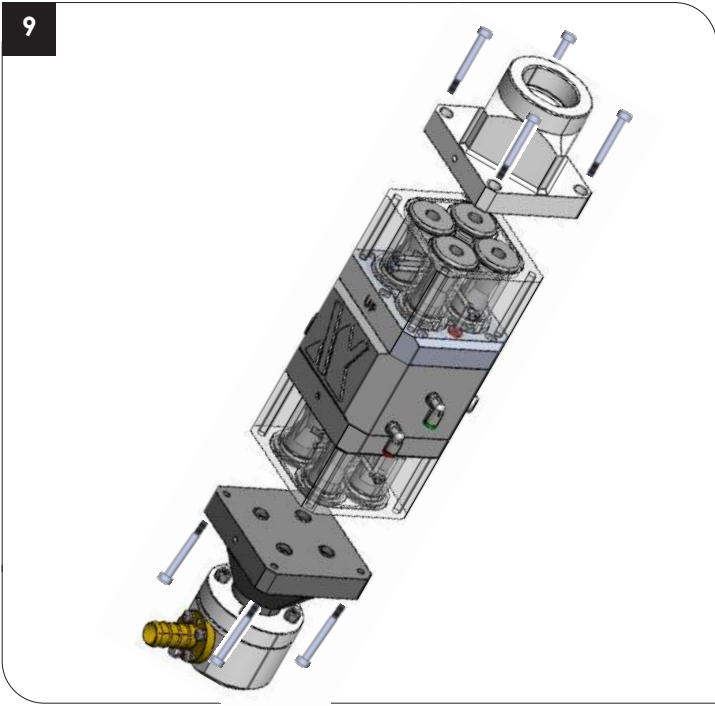
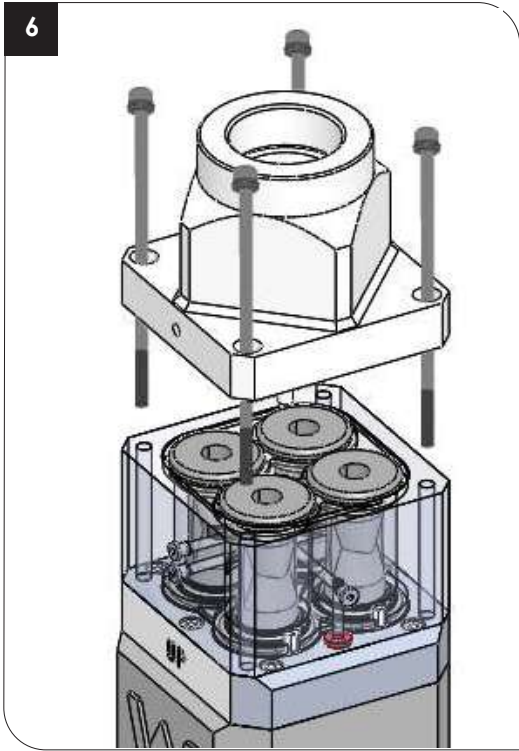

Substitution of the PINCH VALVES



WARNING: Wear eye protection while performing this procedure. The pinch valves will quickly snap back to their normal shape when you pull them out of the pinch valve body.

NOTE: In the upper flanges of the sleeve valves is modeled after the word UP

NOTE: Replace the filter discs (included in the pinch valves kit) when replacing the valves

Pinch Valve Removal



Place the pinch valve body in a padded vise with the bottom end facing you. Grasp and pull the bottom end of the pinch valve with one hand.



Use your other hand to pinch the flange on the opposite end of the pinch valve.



Pull the pinch valve firmly until it comes out of the pinch valve body.

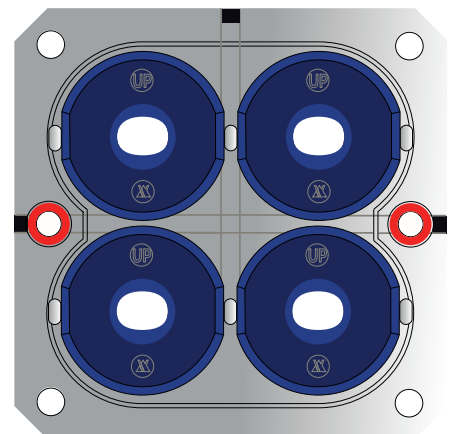

Installing the pinch valves

NOTE: All pinch valves intended for repeated contact with food must be cleaned thoroughly prior to their first use.

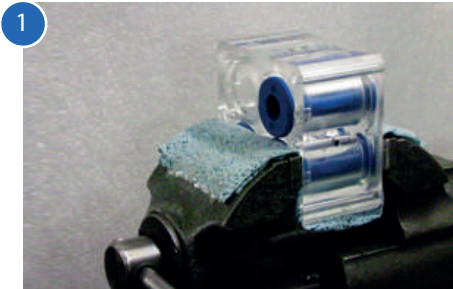

Turn the body of the pinch valves so as to have in front of the upper side.

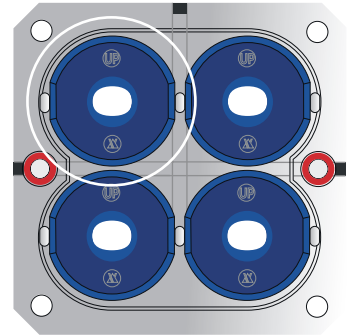

After putting the valve in the tool insertion, flatten the flange on the end of the valve UP.

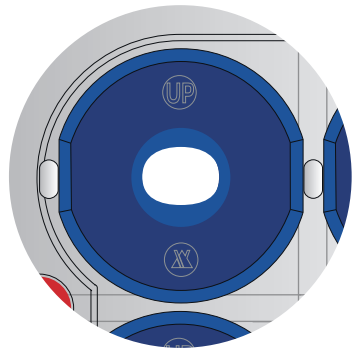

Insert the end of the valve in the tool HIGHER for the insertion of the pinch valves. Compress the UP end of the flange and introduce the small end into the flattened flange, inside the pinch valves.

! NOTES: Observe the straight side of the valve as in the figure or the pinch valves NOT RUN '.



While it compresses the UP end of the flange, pull the tool itself.



Pull the insertion tool through the valve body, until the end of the valve UP and the insertion tool out of the upper side of the body of the pinch valves.

BEHIND VIEW OF PUMP BODY

ITEM	
A	PV1
B	PV2
C	PV3
V	Vacuum
M	Manifold NEA 140

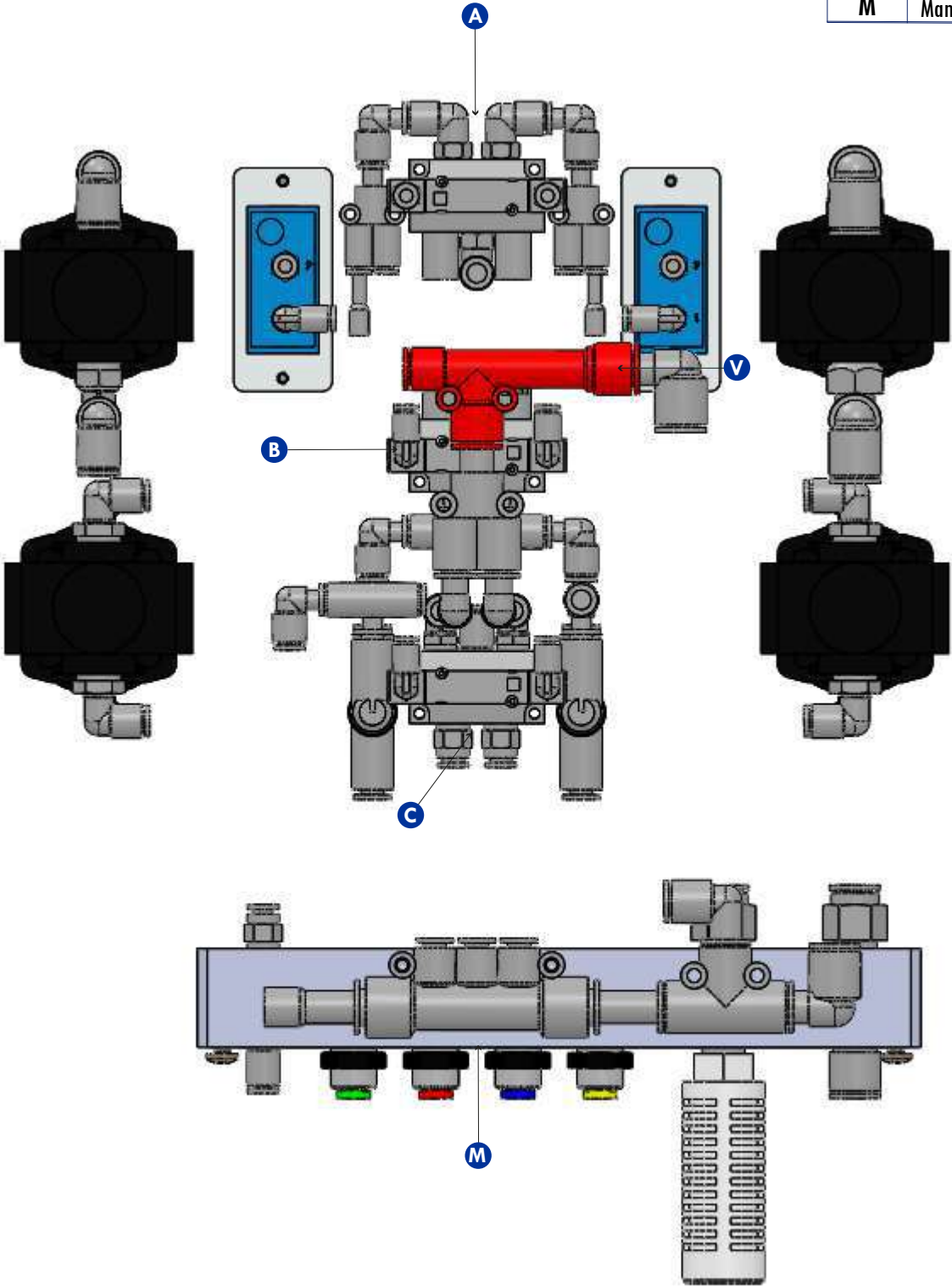

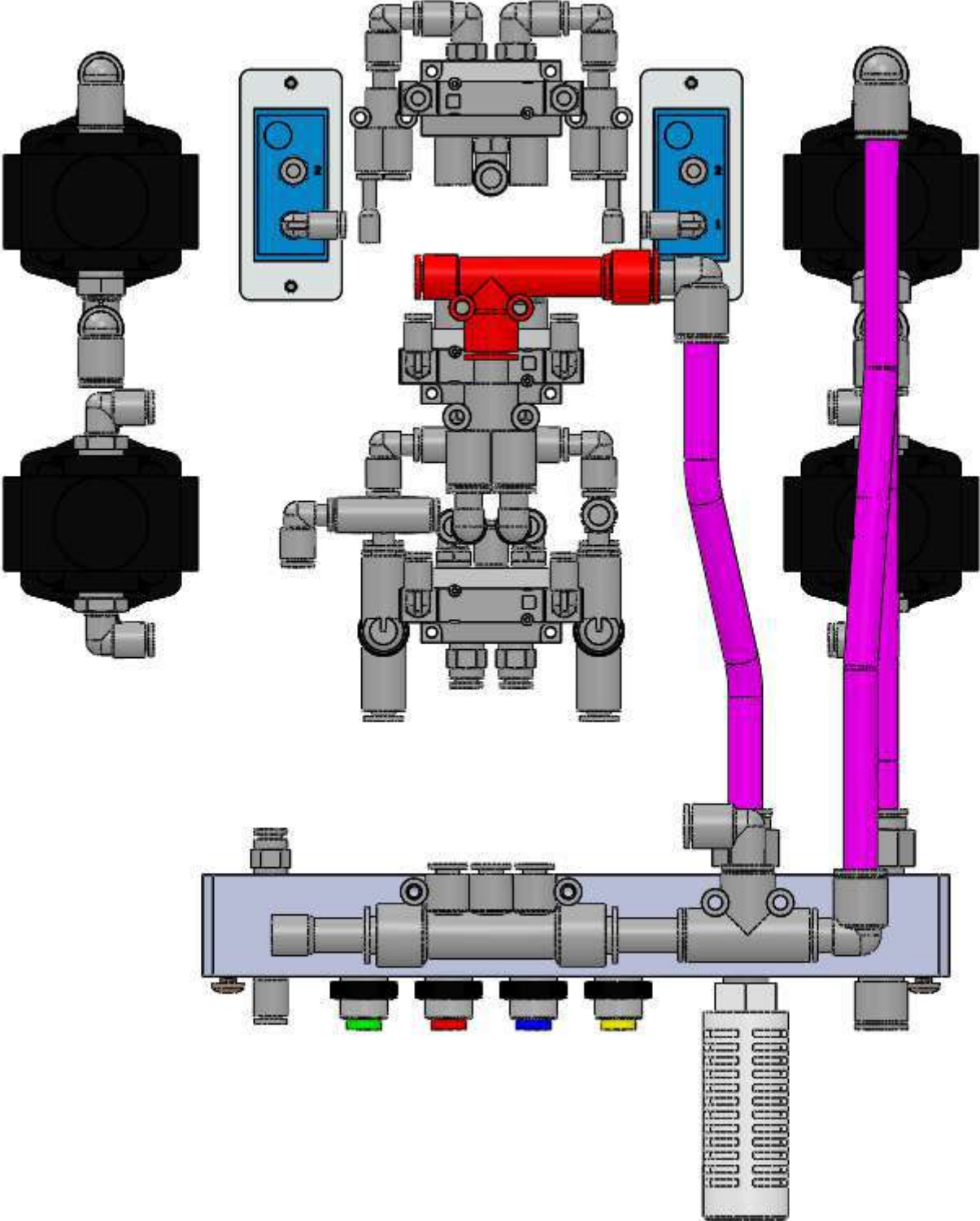

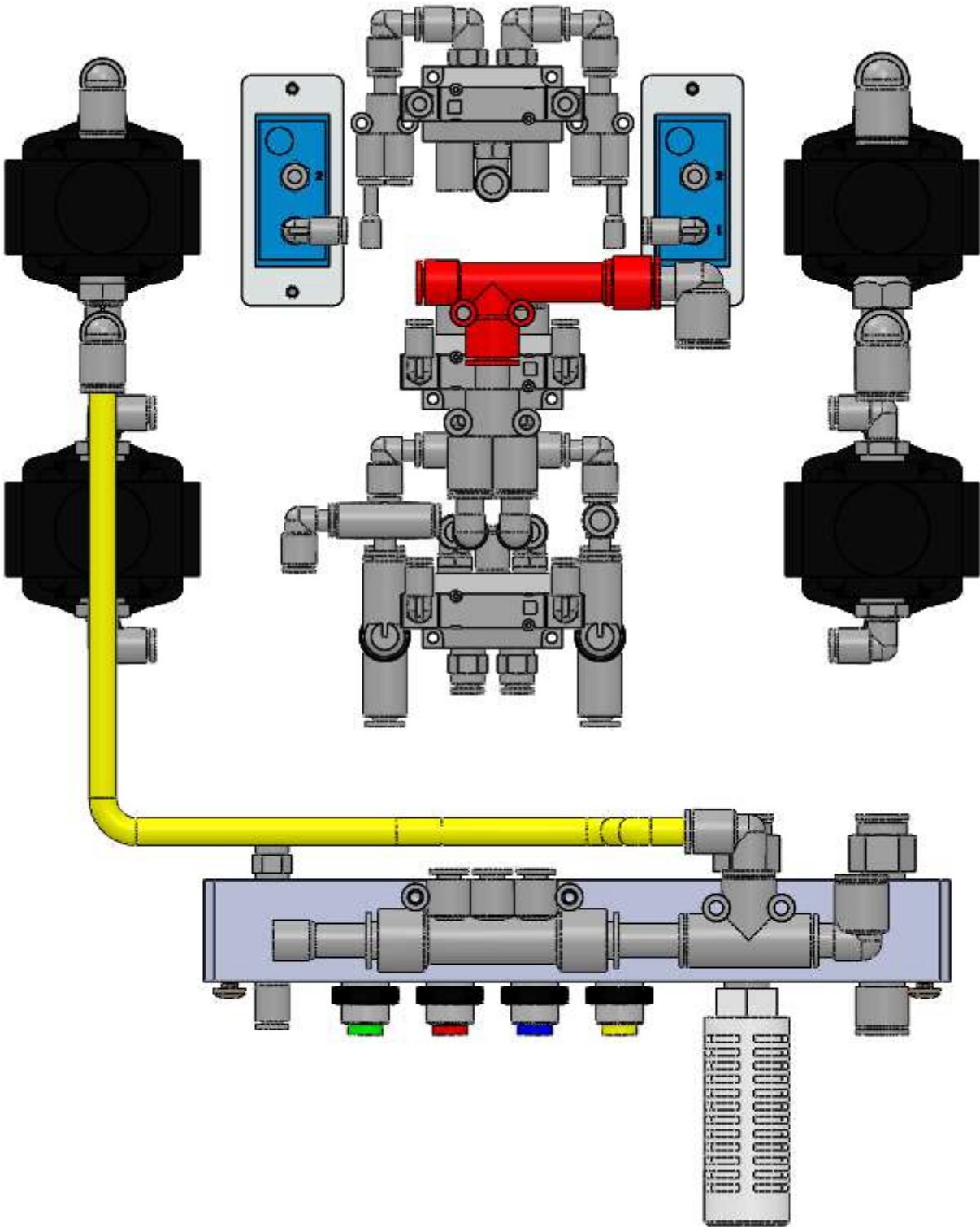

BEHIND and FRONT VIEW OF PUMP BODY

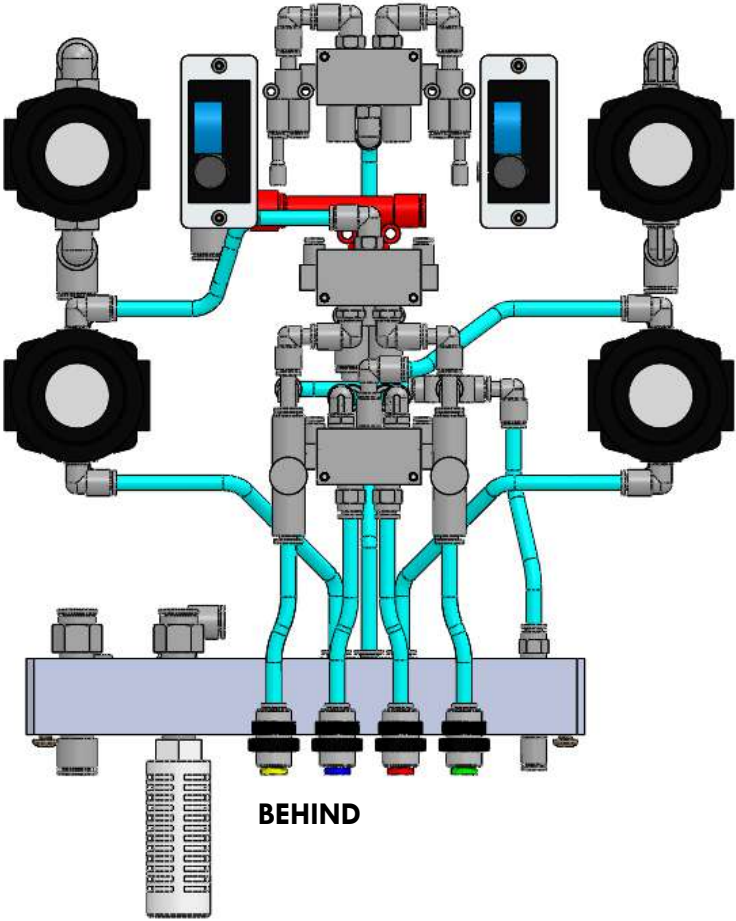
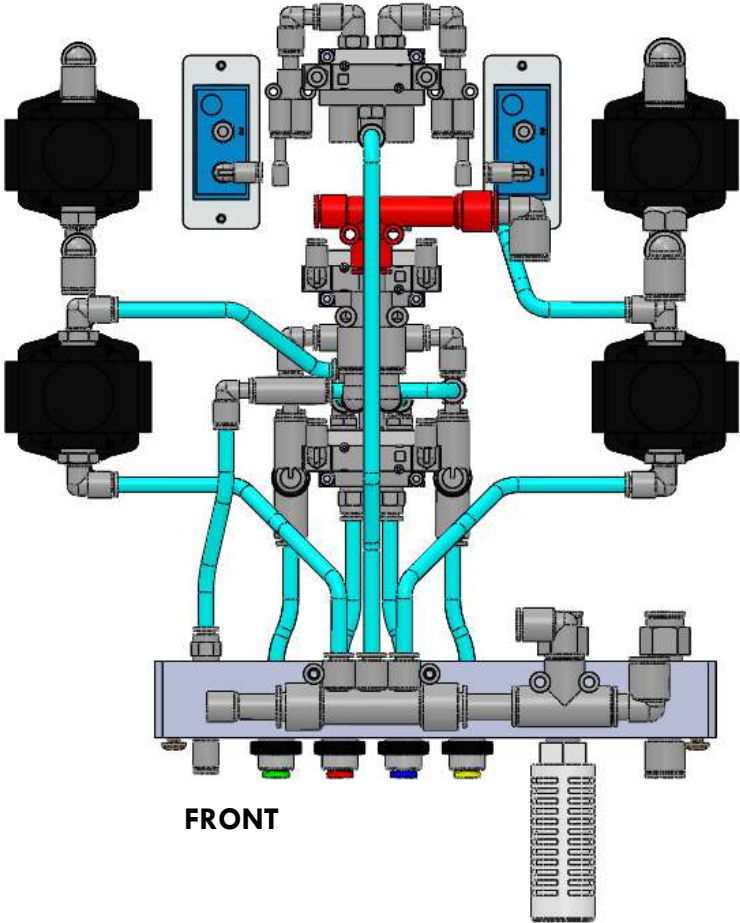

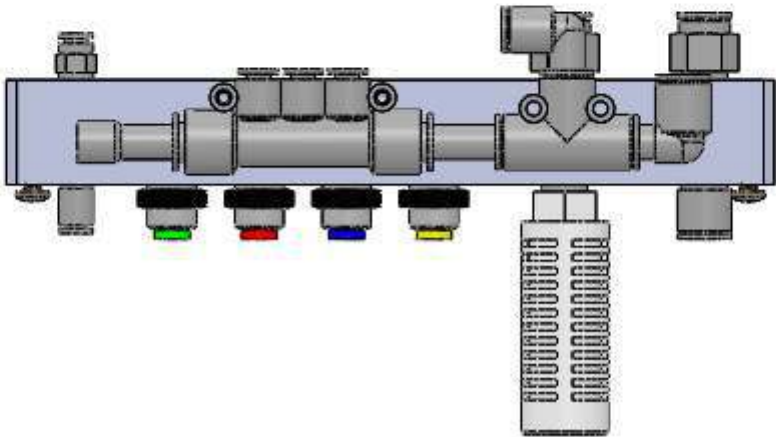
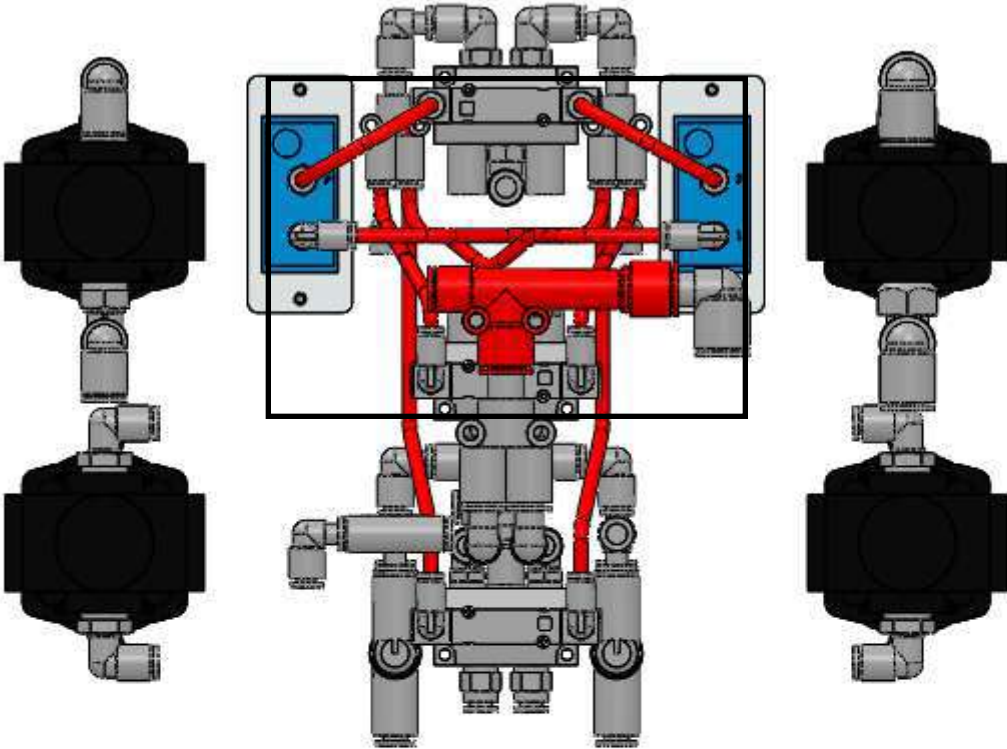
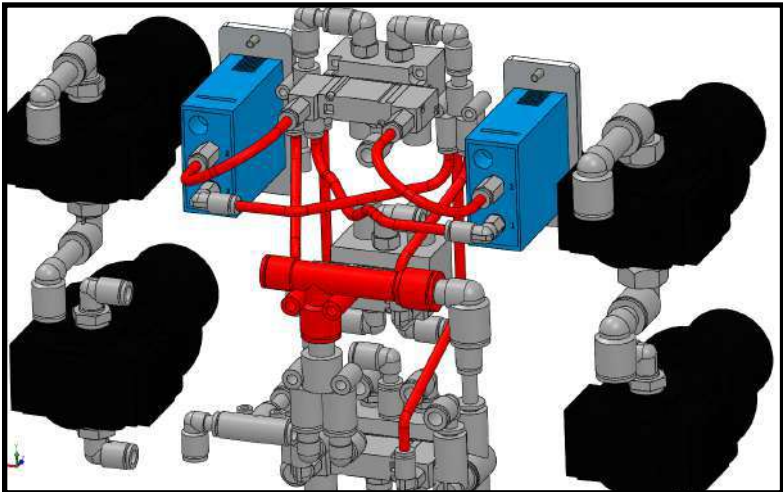

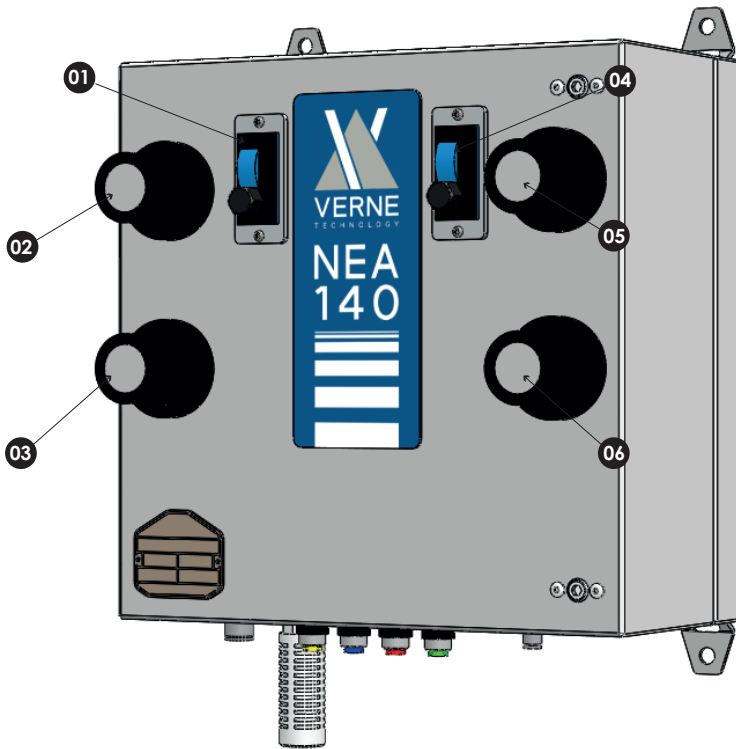

ACRONYM	Part Number (PN)	
01	Timer T0.50	10114
02	Regulator SUPPLY 1/4" 1Mpa_10 10	10025
03	Regulator PINCH VALVES 1/4" 1Mpa_6 6	10026
04	Timer T0.50	10114
05	Regulator VACUUM 1/4" 1Mpa_8 8	10100
06	Regulator TRANSPORT 1/4" 1 Mpa_6 6	10026

ACRONYM	Part Number (PN)	
A	PV1	10103
B	PV2	10115
C	PV3	10116
M	Manifold NEA 140	100031-140
V	Vacuum	10023

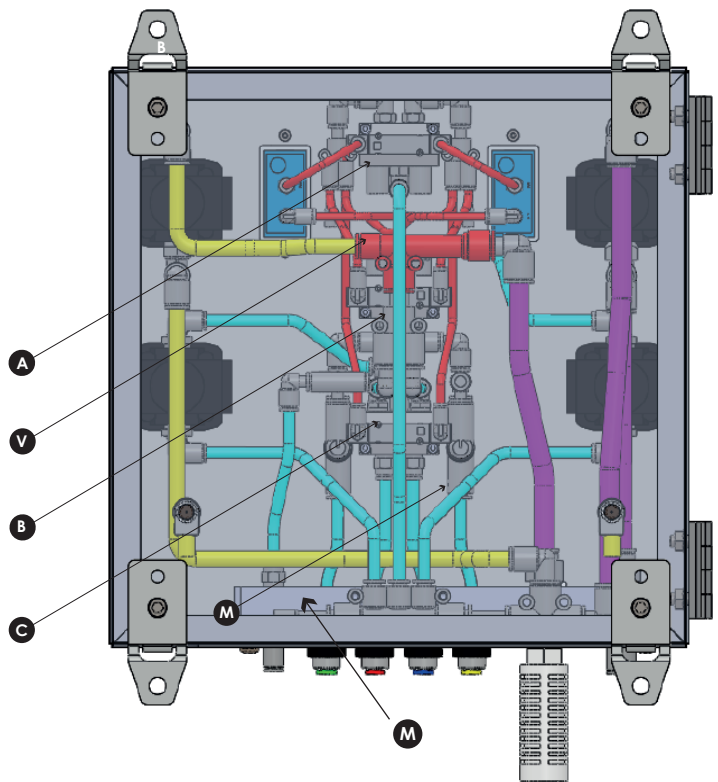

NEA 120 peristaltic dense pump

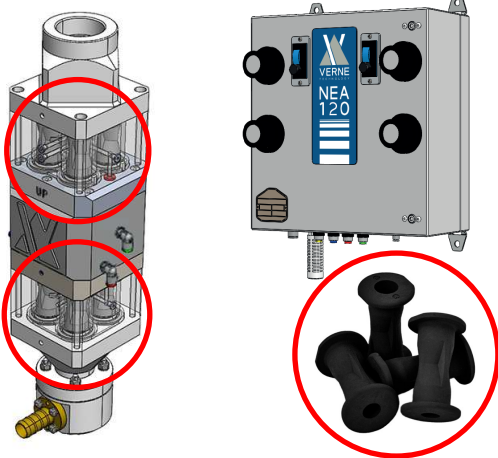
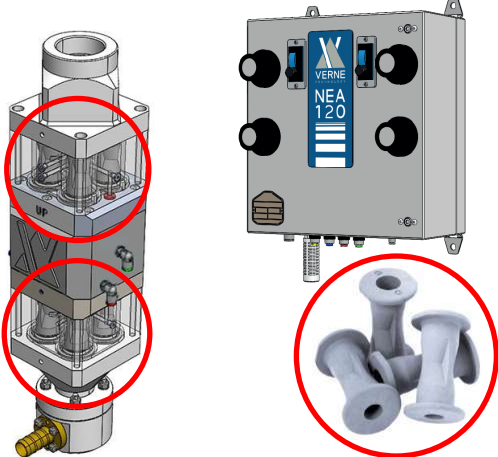
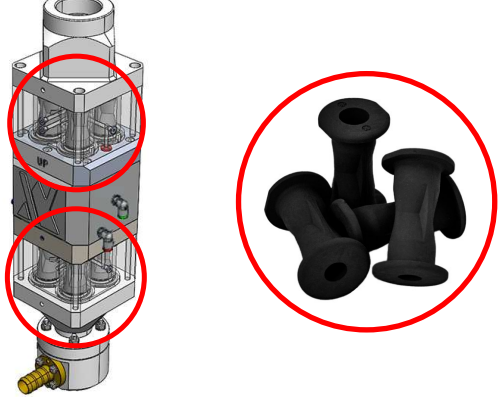
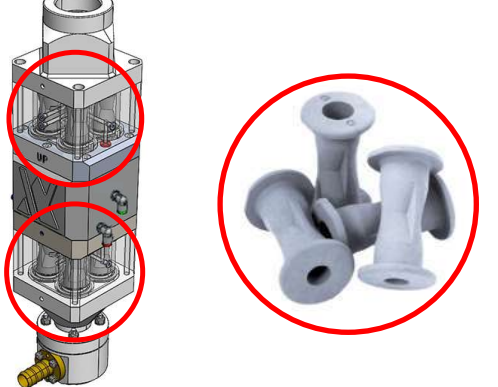
ITEM P/N:	Pcs	Description
<p data-bbox="165 271 327 331">10127-34</p> 	1	NEA 120 (ASSEMBLED) WITH P/N 10034
<p data-bbox="165 757 327 817">10127-35</p> 	1	NEA 120 (ASSEMBLED) WITH P/N 10035
<p data-bbox="165 1243 327 1303">10134-34</p> 	1	PUMP BODY ASSEMBLED -NEA 120- WITH P/N 10034
<p data-bbox="165 1659 327 1720">10134-35</p> 	1	PUMP BODY ASSEMBLED -NEA 120- WITH P/N 10035

NEA 120 peristaltic dense pump

33

ITEM P/N:

Pcs Description

<p>10005</p> 	<p>1 PINCH VALVES HOUSING BODY - NEA 430</p> <p>INCLUDED:</p>
<p>10005-34</p> 	<p>1 PINCH VALVES HOUSING BODY - NEA 430 - WITH PN 10034</p> <p>INCLUDED: 4pcs O-Ring Silicone 3024</p>
<p>10005-35</p> 	<p>1 PINCH VALVES HOUSING BODY - NEA 430-WITH PN 10035</p> <p>INCLUDED: 4pcs O-Ring Silicone 3024</p>
<p>10021</p> 	<p>2 MUFFLER - NEA 430</p>
<p>10023</p> 	<p>2 VACUUM GENERATOR- NEA 430</p>

Inside of NEA pump, there are installed No 2 PN_____.

NEA 120 peristaltic dense pump

34

ITEM P/N:	Pcs	Description
<p>10025</p> 	1	<p>REGULATOR 1/4" - 1Mpa_10 10</p> <p>INCLUDED: All Fittings</p>
<p>10026</p> 	1	<p>REGULATOR 1/4" - 1Mpa_6 6</p> <p>INCLUDED: All Fittings</p>
<p>10031-140</p> 	1	<p>MANIFOLD 140</p> <p>INCLUDED: All Fittings</p>
<p>10034</p> 	4	<p>PINCH VALVES BLACK NO CONDUCTION - NEA 430</p> <p>INCLUDED: 2pcs O-Ring Silicone 3024 2pcs Filter brass Sinterized 1pcs Sheath's mounting</p>
<p>10035</p> 	4	<p>PINCH VALVES GREY - FOOD & PHARMA USE - NEA 430</p> <p>INCLUDED: 2pcs O-Ring Silicone 3024 2pcs Filter brass Sinterized 1pcs Sheath's mounting</p>

Inside of NEA pump, there are installed No 2 PN_____.

NEA 120 peristaltic dense pump



35

ITEM P/N:	Pcs	Description
<p>10082</p> 	<p>2</p>	<p>BRASS ADAPTER d.int.16 mm</p> <p>INCLUDED: 2 pcs brass adapter 2 pcs O-Ring</p>
<p>10083</p> 	<p>2</p>	<p>INOX ADAPTER d.int.16 mm</p> <p>INCLUDED: 2 pcs inox adapter 2 pcs O-Ring</p>
<p>10084</p> 	<p>1</p>	<p>INLET-OUTLET BODY - NEA 440</p>
<p>10086</p> 	<p>1</p>	<p>INLET BODY - NEA 140</p>
<p>10087</p> 	<p>1</p>	<p>INTERMEDIATE BODY - INLET NEA 140</p> <p>INCLUDED: 2 pcs O-Ring 3024 4 pcs O-Ring 130 4 pcs O-Ring 3131</p>

Inside of NEA pump, there are installed No 2 PN_____.

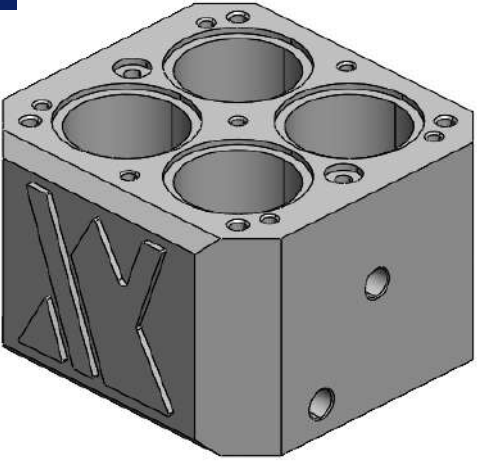
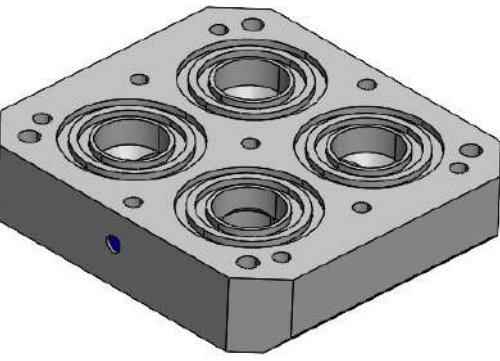

NEA 120 peristaltic dense pump

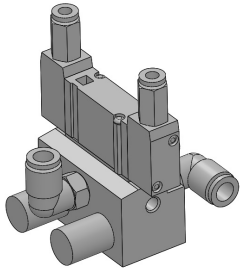
36

ITEM P/N:	Pcs	Description
<p>10135</p> 	<p>1</p>	<p>FLUIDIZING TUBES HOUSING BODY NEA 120</p> <p>INCLUDED: 8 pcs O-Ring Silicone 3131 4 pcs O-Ring Silicone 3024 ALL fittings</p>
<p>10117</p> 	<p>1</p>	<p>INTERMEDIATE BODY - OUTLET NEA 143</p> <p>INCLUDED: 2 pcs O-Ring 3024 4 pcs O-Ring 130 4 pcs O-Ring 3131</p>
<p>10100</p> 	<p>1</p>	<p>REGULATOR 1/4" - 1Mpa_8 8</p> <p>INCLUDED: All Fittings</p>
<p>10103</p> 	<p>1</p>	<p>PV1 - CYCLE VALVE - NEA 440</p> <p>INCLUDED: All Fittings</p>

Inside of NEA pump, there are installed No 2 PN_____.

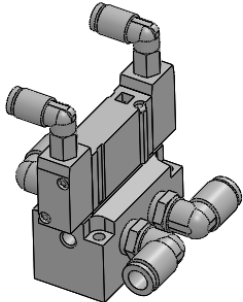
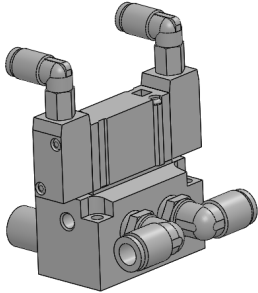
NEA 120 peristaltic dense pump

ITEM P/N:	Pcs	Description
<p>10114</p> 	<p>1</p>	<p>TIMER T 0.50 SEC</p> <p>INCLUDED: All Fittings</p>
<p>10115</p> 	<p>1</p>	<p>PV2- PINCH VALVES - NEA 140</p> <p>INCLUDED: All Fittings</p>
<p>10116</p> 	<p>1</p>	<p>PV3- TUBES VALVE - NEA 140</p> <p>INCLUDED: All Fittings</p>
<p>10136</p> 	<p>4</p>	<p>FLUIDIZING TUBES - NEA 120</p> <p>INCLUDED: All O-Ring</p>

NEA 120 peristaltic dense pump

ITEM P/N:

Pcs Description

<p>10121</p> 	<p>1</p>	<p>GASKET KIT/O-RINGS-PUMP BODY NEA 140</p> <p>INCLUDED: ALL O-Rings</p>
<p>10137</p> 	<p>1</p>	<p>TERMINAL 90° OUTLET - NEA 120</p>
	<p>2</p>	<p>CLOSING ZIPPER ELESA 425611-1-3</p>

NEA 120 peristaltic dense pump

DECLARATION OF CONFORMITY

Model: NEA 120 peristaltic dense pump, Dense phase transfer pump
(High-density powder, low-density air)

Applicable directives:

94/9 / EC (ATEX equipment for use in potentially explosive atmospheres)
98/37 / EEC (Machinery)

Standards used for Compliance:

EN13463-1 EN1127-1
EN12100-1 EN13463-5

Principles:

This product was manufactured in accordance with good engineering practice.
The specified product complies with the directives and standards described above.

Mark flammable atmosphere: Ex II 3 D c T6

Note: The year of equipment manufacture appear in the serial number. "PL20-03"
it means the product was manufactured in 2020, "03" at the end indicate the production lot of the year.

Date: March 01, 2026

Verne Technology S.r.l.
CEO
Carlo Perillo

